

INSTRUCTION SHEET FOR BACKUP ALARMS AND SPECIALTY ALARMS

SAFETY MESSAGE TO INSTALLERS OF BACKUP ALARMS

People's lives depend on your safe installation of our products in conformance with our instructions. It is necessary to read, understand and follow all instructions shipped with the products. In addition, listed below are some other important safety instructions and precautions you should follow.

Failure to follow all safety precautions and instructions may result in property damage, serious injury, or death to you or others you are seeking to protect.

- To properly install a backup alarm: you must have a good understanding of truck and heavy equipment electrical procedures and systems, along with proficiency in the installation and use of safety warning equipment.
- When drilling into a vehicle structure, be sure that both sides of the surface are clear of anything that could be damaged.
- Locate Backup Alarm so it will operate safely under all conditions. The location must provide protection from impact and adverse weather conditions while allowing unobstructed sound projection to the target hazard area.
- Ensure that the vehicle's supply voltage is within the voltage rating specified on the Backup Alarm.
- You should frequently inspect the Backup Alarm system to ensure that it is operating properly and that it is securely attached to the vehicle.
- File these instructions in a safe place and refer to them when maintaining and/or reinstalling the product.

I. GENERAL.

These Backup Alarms are lightweight, low current, piezo-electric, solid-state audible warning devices. The housing is environmentally sealed against moisture, dust, and corrosion.

The compact design only requires 6.7 square inches of surface area for mounting. All units are supplied with a heavy-gauge plated steel universal mounting bracket.

II. SPECIFICATIONS.

Operating Voltage	12-48VDC ±20%
Operating Current	0.10 A @ 12VDC
Pulse Frequency	80 Beeps per minute ±20
Frequency	2400 Hz ±400 Hz
Temperature Range	-40° F to 165° F (-40° C to +74° C)

NOTE

The units are protected against reverse polarity and voltage spikes.

III. KIT CONTENTS LIST.

Qty.	Description	Part No.
1	Bracket, Mounting	430250
2	Screw, Pan Hd., 6-32 x 1/4"	200316
1	Bolt, Hex Hd., 1/4-20 x 3/4"	200333
2	Lockwasher, Int. Tooth, #6	208006
1	Label, Warning	200399

IV. INSTALLATION.

WARNING

Since this alarm is designed to concentrate its audible alarm in the target hazard area only, it should be mounted approximately 4 ft. above ground level with the unit's grill facing the target hazard area.

Select a mounting location at the rear of the vehicle that will provide protection from impact and adverse weather conditions while allowing unobstructed sound projection to the target hazard area.

A suggested location is on the rear of the vehicle, just inside the last cross member or other sturdy part of the body structure. The supplied "L-type" mounting bracket provides mounting flexibility and allows installation in a variety of locations.

A. Electrical.

1. Terminate one end of a user-supplied red (or white) 18 gauge wire with a supplied #6 ring terminal. Terminate one end of a user-supplied black 18 gauge wire with the other #6 ring terminal.

2. Using a #6-32 x 1/4" screw and #6 lockwasher, connect the red (or white) wire to the "+" terminal on the alarm. Using a #6-32 x 1/4" screw and #6 lockwasher, connect the black wire to the "-" terminal on the alarm.

3. Route the other end of the red (or white) wire to the vehicle's backup light circuit, or to an independent actuating switch. DO NOT connect the red (or white) wire to the backup-light circuit, or to the independent actuating switch, at this time.

WARNING

Improper grounding could result in death or serious injury to those who rely on this device for safety. The ground connection (-) MUST be attached to a solid metal body or chassis part that will provide a dependable ground path as long as the device is to be used.

4. Connect the other end of the black wire to a known good chassis ground.

B. Mechanical.

1. Mounting Bracket (see figure 1).
 - a. Using the bracket as a template, scribe four drill position marks on the mounting surface.

CAUTION

Before drilling holes in ANY part of a vehicle, be sure that both sides of the mounting surface are clear of parts that could be damaged, such as brake lines, fuel lines, electrical wiring or other vital parts.

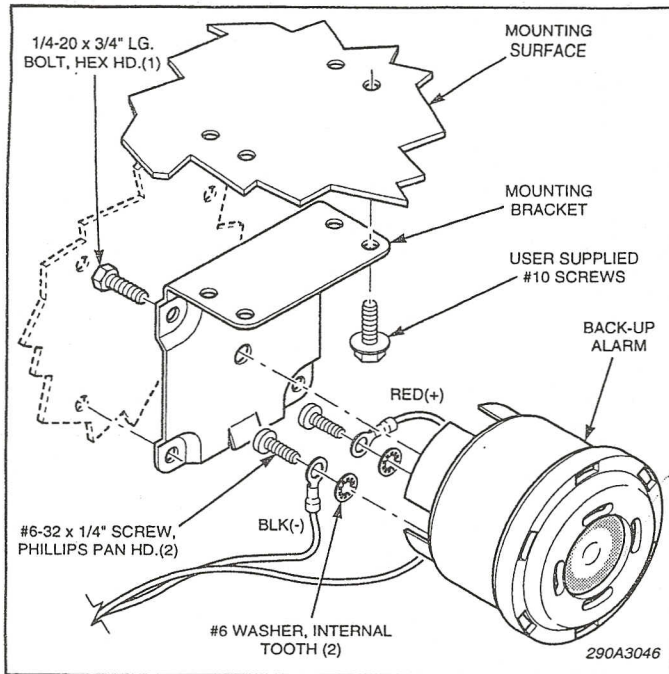

Figure 1.

b. Drill four mounting holes (size determined by the user-supplied mounting bolts) at the drill position marks.

c. Attach the alarm to the mounting bracket using the 1/4-20 x 3/4" hex head bolt and tighten the bolt completely into the alarm. Ensure that the wires are not pinched between the bracket and the alarm.

d. Secure the bracket/alarm assembly to the mounting surface with user-supplied #10 screws.

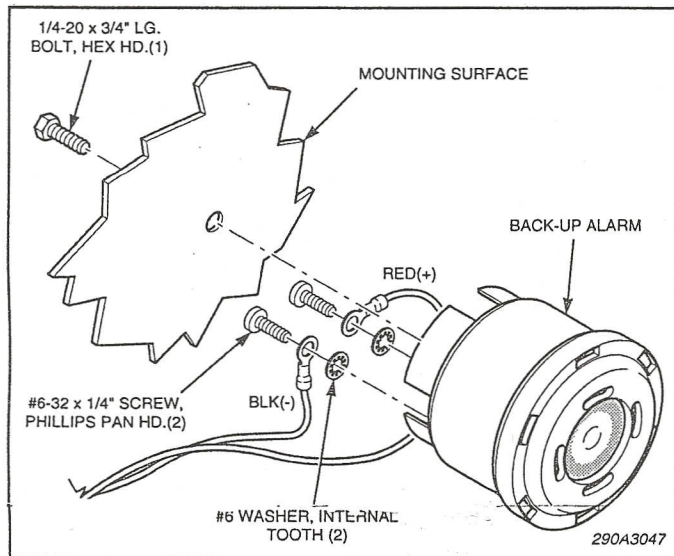

Figure 2.

2. Surface Mounting (see figure 2).

a. Scribe a drill position mark at the desired location.

CAUTION

Before drilling holes in ANY part of a vehicle, be sure that both sides of the mounting surface are clear of parts that could be damaged; such as brake lines, fuel lines, electrical wiring or other vital parts.

b. Drill a 0.281" hole in the mounting surface.

c. Attach the alarm to the mounting surface using the 1/4-20 x 3/4" hex head bolt and tighten the bolt completely into the alarm. Ensure that the wires are not pinched between the mounting surface and the alarm.

C. Final Installation and Testing.

1. See figure 3. Connect the red (or white) wire to the vehicle's backup light circuit, or to an independent actuating switch.

2. Install the WARNING label in a location clearly visible to the operator at all times.

3. Test the backup alarm for proper operation.

SAFETY MESSAGE TO OPERATORS OF BACKUP ALARMS

- Should the alarm become inoperative, it could jeopardize the safety or lives of those who depend on the alarm signal for safety.
- Testing the Backup Alarm should be listed on the daily maintenance report. The units on operating vehicles must be tested each day prior to the vehicles' operation. Results of this test must be recorded in the maintenance file.
- Notify your supervisor that people operating this equipment **MUST** check for proper operation at the beginning of every shift.

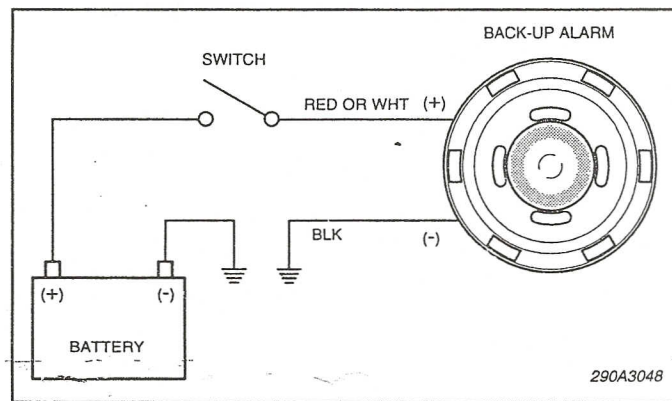

Figure 3.