

Installation Instructions

Jeep Cherokee

Jeep Wagoneer (Downsized Model)

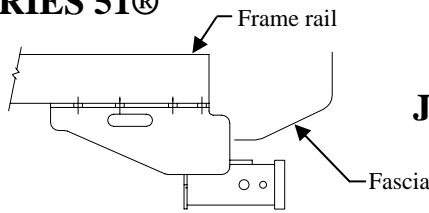

**Do Not Exceed Lower of Towing Vehicle
Manufacturer's Rating or**

Hitch Shown In Proper Position

Equipment Required: Chisel, Pullwire (provided)

Fastener Kit: 51001-051

Wrenches: 18mm, 3/4, 13/16, 7/8

Drill Bits: None

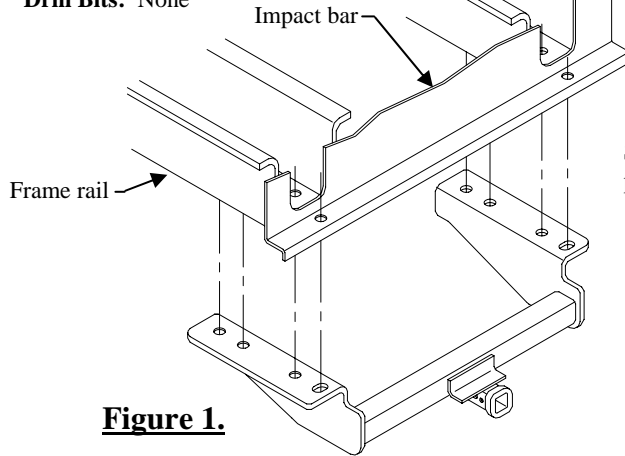
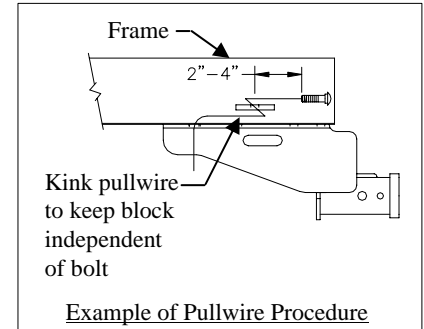

Figure 1.

Hitch type	Max Gross Trailer WT (LB)	Max Tongue WT (LB)
Weight Distributing	5000 (2270 Kg)	500 (227 Kg)
Weight Carrying Ball Mount	3500 (1589 Kg)	300 (136 Kg)

Wiring Access Location: SUV1, SUV2

See Figures 2, 3, 4 & 5 for proper fastener combinations



Note: Five (5) installation options are possible depending on vehicle configuration refer to Figures 2, 3, 4 and 5.

1. Remove all but a thin layer of undercoating from attaching surfaces. Also, grind or chisel off small aluminum rivet heads if present on attaching surfaces. This will ensure side brackets will sit flat against the frame.

2. **Option A** – See Figure 2.

1996 and earlier vehicles equipped with frame mounted, closed sides, steel skid shield.

A. Remove rear skid shield mounting bolt and loosen the forward skid shield mounting bolt, each side so that the skid shield is lowered about 1/4".

Note: DO NOT REMOVE forward mounting bolt at this time or skid shield will come off:

B. Raise hitch into position, putting the receiver flange between the frame and the skid shield.

C. Install four (4) M12 bolts with lock washers provided (the rearmost attachment has a hardened flat washer between receiver flange and lock washer). Each side as shown in Figure 1.

D. At this time, remove forward skid shield mounting bolts. Place two (2) 1/2" flat washers as spacers between frame and skid shield and reinstall existing M12 fastener.

Option B – See Figure 5

1997 and later vehicles equipped with frame mounted, closed sided, steel skid shield:

A. Remove the rear skid shield bolts on each side. Drill hole thru skid shield being careful not to damage weldnut in frame.

B. Raise hitch into position placing the hitch over the skid shield flanges.

C. Install four (4) M12 bolts with conical washers provided (the rearmost attachment has a hardened flat washer between receiver flange and lock washers), each side as shown in Figure 5.

Option C – See Figures 2 & 3

Vehicles equipped with frame mounted tow hook on driver's side:

A. Remove tow hook and tow hook bracket; Return component to vehicle owner. Mount driver's side of receiver using M12 bolts as shown in Figure 1. Mount passenger side of receiver as shown in Figure 3.

Option D – See Figure 3

Vehicles not equipped with frame mounted, closed sided, steel skid shield or frame mounted tow hook:

A. Using pullwire feed 1/4 X 1-1/2 X 2 blocks (Item 9 & 10) and carriage bolts through end of frame and into existing holes. Raise hitch into position and attach per Figure 3.

Option E – See Figure 4

Vehicles with passenger side exhaust hanger studs;

A. Remove (2) nuts from exhaust hanger. Rubber hanger in front of rear axle can be detached to allow exhaust pipe to drop further.

B. Install hitch using M12 bolts to existing weld nuts or 1/2-13 bolts with blocks to open holes as shown.

C. Attach exhaust hanger to studs with original nuts.

Note: Use pullwire to feed blocks through end of frame in orientation shown in Figure 4. Removal of bumper (4 bolts per side) may ease process.

3. Install all remaining fasteners as shown.

Tighten 1/2 GR5 fasteners with torque wrench to 75 Lb.-Ft. (102 N*M)

Tighten 1/2 Handle Nut fasteners with torque wrench to 50 Lb.-Ft. (68 N*M)

Tighten M12 CL 8.8 fasteners with torque wrench to 68 Lb.-Ft. (92 N*M)

Note: check hitch frequently, making sure all fasteners and ball are properly tightened. If hitch is removed, plug all holes in trunk pan or other body panels to prevent entry of water and exhaust fumes. A hitch or ball which has been damaged should be removed and replaced. Observe safety precautions when working beneath a vehicle and wear eye protection. Do not cut access or attachment holes with a torch.

This product complies with safety specifications and requirements for connecting devices and towing systems of the state of New York, V.E.S.C. Regulation V-5 and SAE J684.

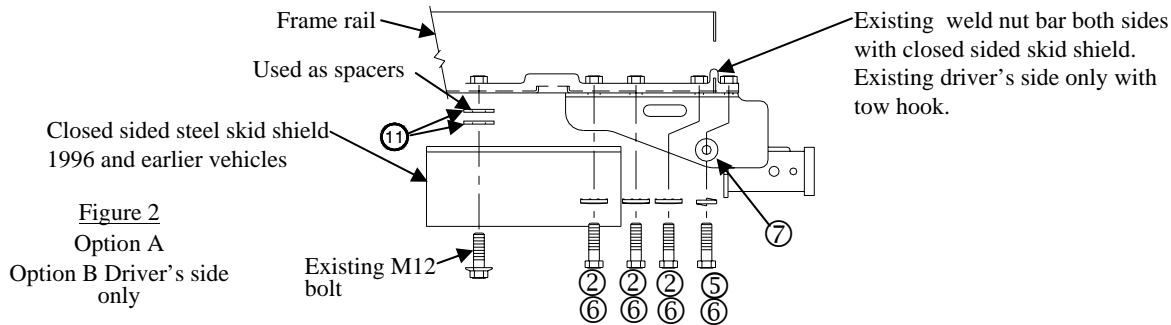

Figure 2

Option A

Option B Driver's side only

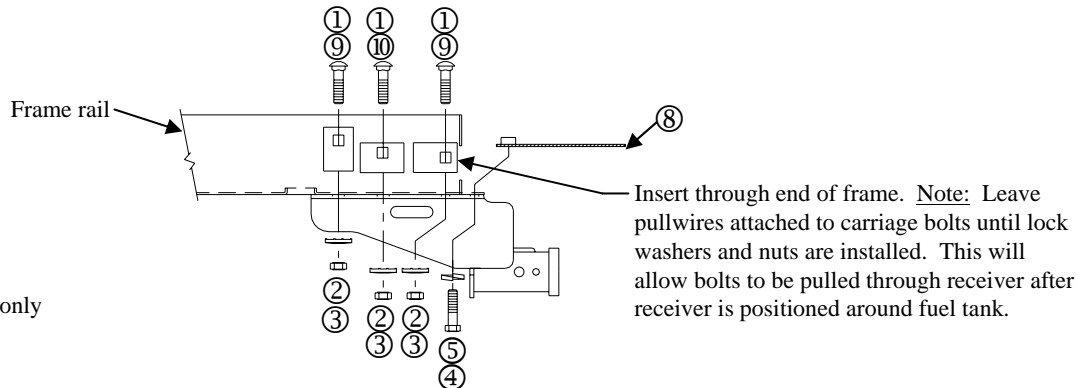

Figure 3

Option C Passenger only

Option D

①	Qty. (6)	Carriage Bolt 1/2-13 X 1.75	⑦	Qty. (2)	Flat Washer (Hardened)
②	Qty. (6)	Conical Washer 1/2	⑧	Qty. (2)	Nut Assy-Handle 1/2-13
③	Qty. (6)	Hex Nut 1/2-13	⑨	Qty. (4)	Block 1/4 X 1-1/2 X 2
④	Qty. (2)	Hex Bolt 1/2-13 X 1.50	⑩	Qty. (2)	Block 1/4 X 1-1/2
⑤	Qty. (2)	Lock Washer 1/2	⑪	Qty. (4)	Flat Washer 1/2 (Used as a Spacer)
⑥	Qty. (8)	Hex Bolt M12 X 1.75 X 40			

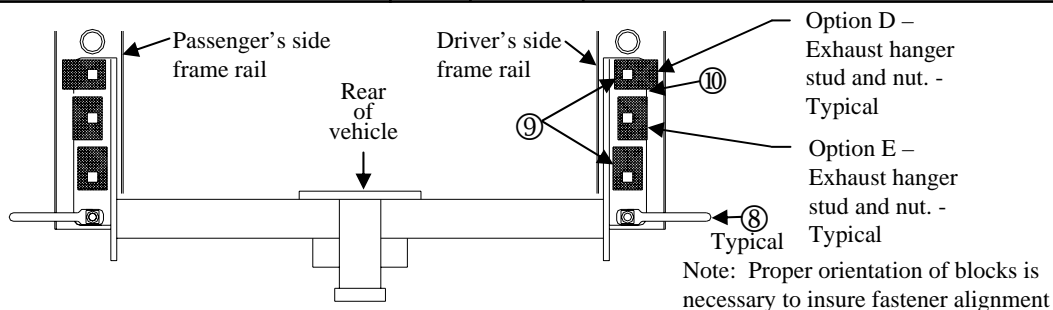

Figure 4

Viewed from under vehicle looking up

Note: Proper orientation of blocks is necessary to insure fastener alignment

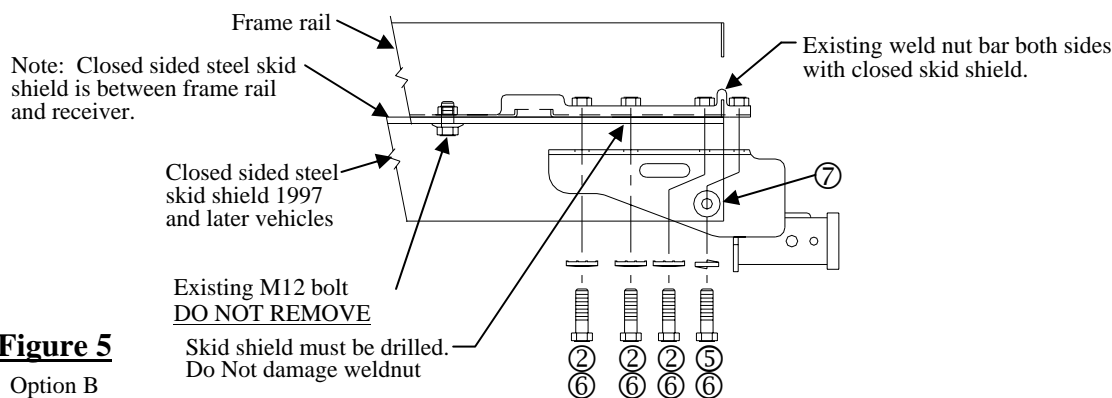

Figure 5

Option B

Note: check hitch frequently, making sure all fasteners and ball are properly tightened. If hitch is removed, plug all holes in trunk pan or other body panels to prevent entry of water and exhaust fumes. A hitch or ball which has been damaged should be removed and replaced. Observe safety precautions when working beneath a vehicle and wear eye protection. Do not cut access or attachment holes with a torch.

This product complies with safety specifications and requirements for connecting devices and towing systems of the state of New York, V.E.S.C. Regulation V-5 and SAE J684.