



Update Alert: Firmware updates are posted to the web on a regular basis. We recommend that you check for firmware and/or install guide updates prior to installing this product.

Installation Guide

The CHRYSLER firmware for DBALL2 is an all-in-one door lock and override module compatible with specific Chrysler, Dodge, Jeep and Volkswagen vehicles.

 This module can only be flashed and configured using DirectLink at www.directechs.com or using the Directechs Mobile application for smartphones. Refer to the Module Programming section on pages 21-22 for more information.



Index

Vehicle Application Guide.....	02
Installation	
Type 1a (with CHTHD1/THCHD1 T-Harness R7).....	03
Type 1b (with CHTHD1/THCHD1 T-Harness R1-R6).....	04
Type 1c (without T-Harness).....	05
Vehicle wiring reference chart (Type 1).....	06
Type 2a (with CHTHD1/THCHD1 T-Harness R7).....	08
Type 2b (with CHTHD1/THCHD1 T-Harness R1-R6).....	09
Type 2c (without T-Harness).....	10
Vehicle wiring reference chart (Type 2).....	11
Type 3a (with CHTHD2/THCHD2 T-Harness R9).....	12
Type 3b (with CHTHD2/THCHD2 T-Harness R1-R6).....	13
Type 3c (without T-Harness).....	14
Vehicle wiring reference chart (Type 3).....	15
Type 4.....	17
Vehicle wiring reference chart (Type 4).....	18
Type 5.....	19
Vehicle wiring reference chart (Type 5).....	20
Programming	
Module Programming - Vehicles WITH Factory Keyless.....	21
Module Programming - Vehicles WITHOUT Factory Keyless.....	22
Module Reset.....	23
Hard Reset.....	23
Feature & Option List.....	24
Feature Programming.....	25
LED Diagnostics & Troubleshooting.....	26
Limited One-Year Consumer Warranty.....	27
Quick Reference Guide.....	28

Vehicle Application Guide

The following table lists the vehicles and features which are compatible with this product. The number assigned to each year allows you to determine which installation type should be used for your vehicle.

Vehicles	2016	2015	2014	2013	2012	2011	2010	2009	2008	2007	2006	2005	2004	PK-Immobilizer Bypass-Data No Key Req'd	AV-Parking Lights Control	CC-Heated Seats Activation	DL-Arm Factory Security	DL-Disarm Factory Security	DL-Door Lock Control	DL-Door Unlock	DL-Driver Priority Unlock	DL-Sliding Door Control Driver	DL-Sliding Door Control Passenger	DL-Trunk / Hatch Release	FOB-Control of aftermarket alarm with OEM remote	RS-RAP Shut Down (Retained ACC Power)	RS-Tach / RPM Output	SS-Entry Monitoring ALL Door Pins	SS-Entry Monitoring Driver Door Pin	SS-Entry Monitoring Trunk/Hatch Pin	ST-Brake Status (foot brake)	ST-E-Brake Status
Chrysler																																
200			3	3	3	3								*		*	*	*	*	*	*	*	*	*	D	*	*	*	D	*	*	*
300/300c							2	2	2					*	W	*	*	*	*	*	*	*	*	*	D	*	*	*	D	*	*	*
300/300c										4	4	4		*		*	*	*	*	*	*	*	*	D	*	*	*	D	*	*	*	
Aspen							3	3	3					*		*	*	*	*	*	*	*	*	D	*	*	*	D	*	*	*	
PT Cruiser							4	4	4	4	4			*		*	*	*	*	*	*	*	*	D	*	*	*	D	*	*	*	
Sebring							3	3	3	3	3			*		*	*	*	*	*	*	*	*	D	*	*	*	D	*	*	*	
Sebring Convertible							3	3	3					*		*	*	*	*	*	*	*	*	D	*	*	*	D	*	*	*	
Sebring Sedan							3	3	3	3	3			*		*	*	*	*	*	*	*	*	D	*	*	*	D	*	*	*	
Town & Country	1	1	1	1	1	1	1	1	1					*	W	*	*	*	*	*	*	*	*	D	*	*	*	D	*	*	*	
Dodge/Ram																																
1500					1	1								*	W	*	*	*	*	*	*	*	*	D	*	*	*	D	*	*	*	
2500					1	1								*	W	*	*	*	*	*	*	*	*	D	*	*	*	D	*	*	*	
3500					1	1								*	W	*	*	*	*	*	*	*	*	D	*	*	*	D	*	*	*	
Avenger			3	3	3	3	3	3	3					*		*	*	*	*	*	*	*	*	D	*	*	*	D	*	*	*	
C/V	1	1	1	1	1	1								*	W	*	*	*	*	*	*	*	*	D	*	*	*	D	*	*	*	
Caliber					3	3	3	3	3	3 or 4*				*		*	*	*	*	*	*	*	*	D	*	*	*	D	*	*	*	
Caravan						1	1	1	1					*	W	*	*	*	*	*	*	*	*	D	*	*	*	D	*	*	*	
Challenger			1	1	1	1	1	1	1					*	W	*	*	*	*	*	*	*	*	D	*	*	*	D	*	*	*	
Challenger (Smart Key)			1	1	1	1	1	1	1					*	W	*	*	*	*	*	*	*	*	D	*	*	*	D	*	*	*	
Charger						2	2	2						*	W	*	*	*	*	*	*	*	*	D	*	*	*	D	*	*	*	
Charger										4	4			*		*	*	*	*	*	*	*	*	D	*	*	*	D	*	*	*	
Dakota						3	3	3	3	3				*		*	*	*	*	*	*	*	*	D	*	*	*	D	*	*	*	
Dakota											5	5		*		*	*	*	*	*	*	*	*	D	*	*	*	D	*	*	*	
Durango				1	1	1								*	W	*	*	*	*	*	*	*	*	D	*	*	*	D	*	*	*	
Durango							3	3	3	3				*		*	*	*	*	*	*	*	*	D	*	*	*	D	*	*	*	
Durango											5	5	5	*		*	*	*	*	*	*	*	*	D	*	*	*	D	*	*	*	
Grand Caravan	1	1	1	1	1	1	1	1	1					*	W	*	*	*	*	*	*	*	*	D	*	*	*	D	*	*	*	
Journey						1	1							*		*	*	*	*	*	*	*	*	D	*	*	*	D	*	*	*	
Magnum								2						*	W	*	*	*	*	*	*	*	*	D	*	*	*	D	*	*	*	
Magnum										4	4	4		*		*	*	*	*	*	*	*	*	D	*	*	*	D	*	*	*	
Nitro						3	3	3	3	3				*		*	*	*	*	*	*	*	*	D	*	*	*	D	*	*	*	
RAM						1	1							*	W	*	*	*	*	*	*	*	*	D	*	*	*	D	*	*	*	
RAM									3 or 4*	3 or 4*	3 or 4*			*		*	*	*	*	*	*	*	*	D	*	*	*	D	*	*	*	
Jeep																																
Commander						2	2	2	4	4				*		*	*	*	*	*	*	*	*	D	*	*	*	D	*	*	*	
Compass	3	3	3	3	3	3	3	3	3	3				*		*	*	*	*	*	*	*	*	D	*	*	*	D	*	*	*	
Grand Cherokee				1	1	1								*	W	*	*	*	*	*	*	*	*	D	*	*	*	D	*	*	*	
Grand Cherokee							2	2						*		*	*	*	*	*	*	*	*	D	*	*	*	D	*	*	*	
Grand Cherokee										4	4	4		*		*	*	*	*	*	*	*	*	D	*	*	*	D	*	*	*	
Grand Cherokee (Smart Key)				1	1	1								*	W	*	*	*	*	*	*	*	*	D	*	*	*	D	*	*	*	
Liberty					3	3	3	3	3					*		*	*	*	*	*	*	*	*	D	*	*	*	D	*	*	*	
Patriot	3	3	3	3	3	3	3	3	3	3				*		*	*	*	*	*	*	*	*	D	*	*	*	D	*	*	*	
Wrangler	3	3	3	3	3	3	3	3	3	3				*		*	*	*	*	*	*	*	*	D	*	*	*	D	*	*	*	
Mitsubishi																																
Raider							3	3	3					*		*	*	*	*	*	*	*	*	D	*	*	*	D	*	*	*	
Raider											5			*		*	*	*	*	*	*	*	*	D	*	*	*	D	*	*	*	
Volkswagen																																
Routan			1	1	1	1	1							*	W	*	*	*	*	*	*	*	*	D	*	*	*	D	*	*	*	

Legend:

*: D2D & Wire-to-Wire (W2W)
W: Wire-to-Wire

AV: Horn & Lights Controls
PK: Transponder & Immobilizer Override
CC: Comfort & Convenience Control

RS: Remote Start & Engine Controls
DL: OE Door Lock & Alarm Controls
SS: Integrated Security & Monitoring
ST: Function/Feature Status

* To select the proper install type, locate the ignition switch connector and select your install type as illustrated below:

Type 3 vehicles do not have a (+) Starter wire at the ignition switch

5 or 6

Connector side view at ignition switch

OR

Type 4 vehicles have a (+) Starter wire at pin 4 of the ignition switch

5 or 6

Connector side view at ignition switch

Installation Type 1a (with CHTHD1/THCHD1 T-Harness R7)

⚠️ Refer to the Vehicle Wiring Reference Charts on pages 6-7 for wire color and location.

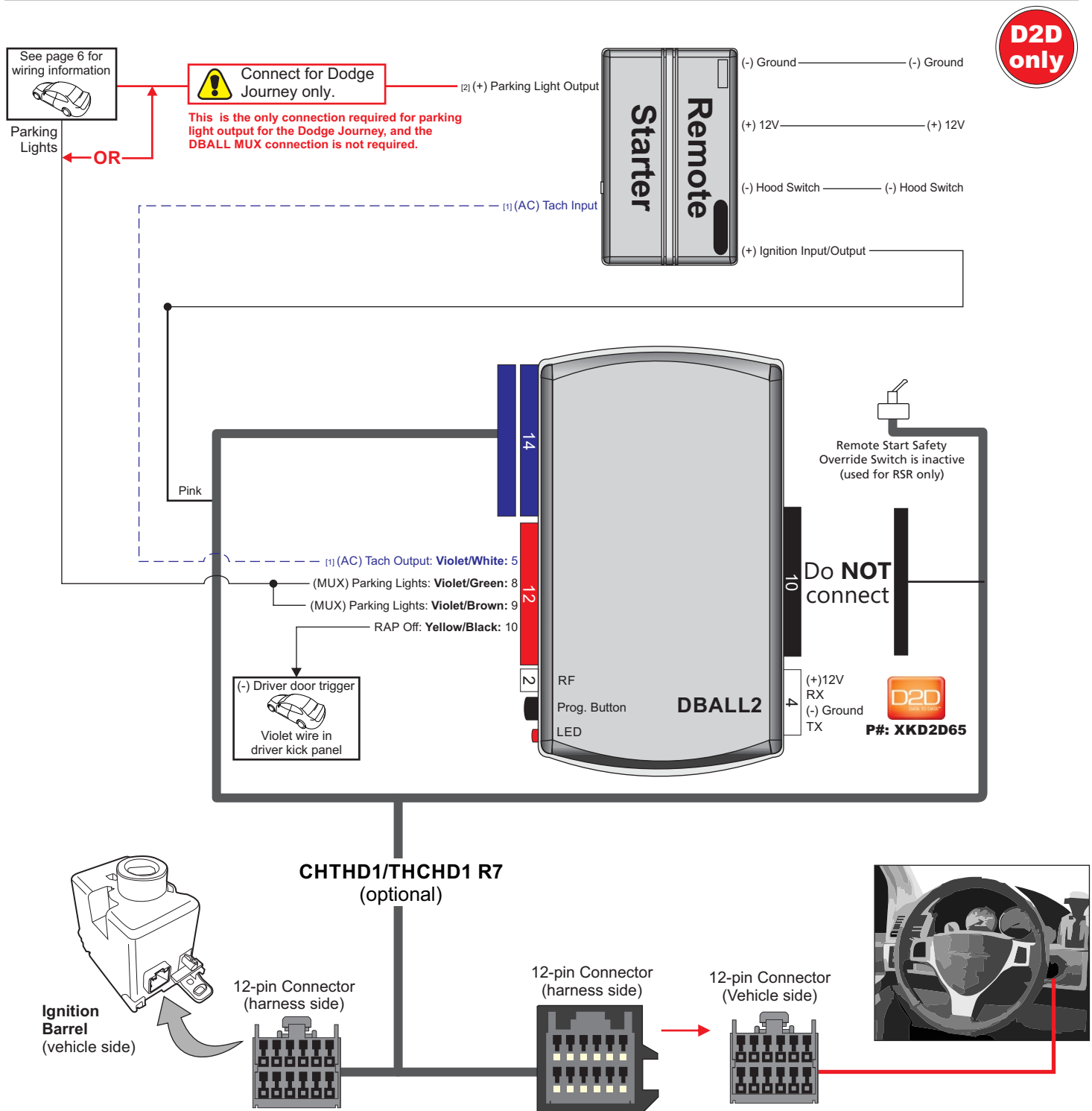

[1] Tach wire is an optional connection required on some remote starters, which do not support a tach signal in D2D.

[2] Connection only required for Dodge Journey.

⚠️ Wires not listed in this diagram are not required for the installation.

⚠️ All adapters are displayed from the wire side (unless specified otherwise).

Installation Type 1b (with CHTHD1/THCHD1 T-Harness R1-R6)

⚠️ Refer to the Vehicle Wiring Reference Charts on pages 6-7 for wire color and location.

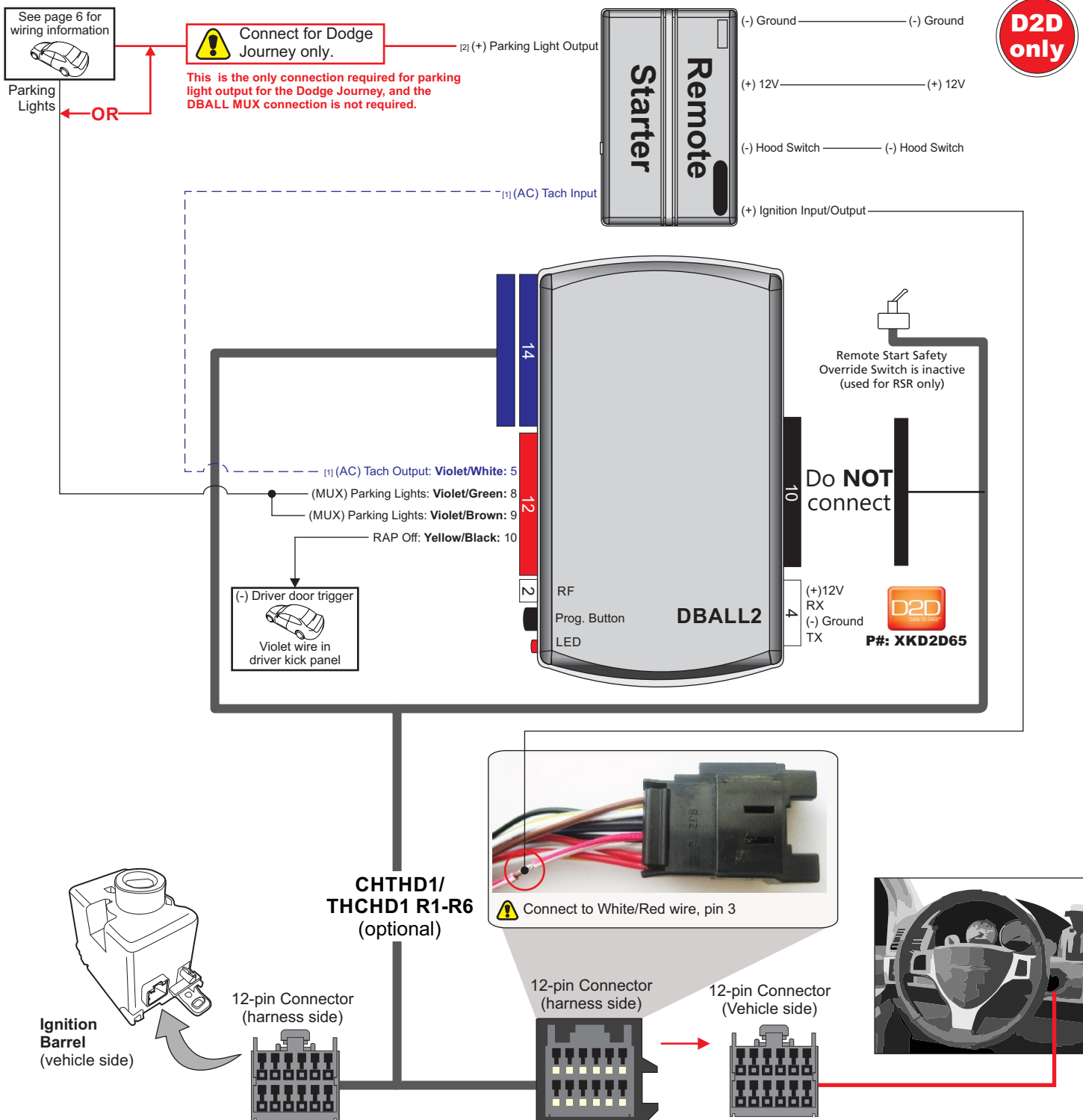

[1] Tach wire is an optional connection required on some remote starters, which do not support a tach signal in D2D.

[2] Connection only required for Dodge Journey.

⚠️ Wires not listed in this diagram are not required for the installation.

⚠️ All adapters are displayed from the wire side (unless specified otherwise).

Installation Type 1c (without T-Harness)

⚠️ Refer to the Vehicle Wiring Reference Charts on pages 6-7 for wire color and location.

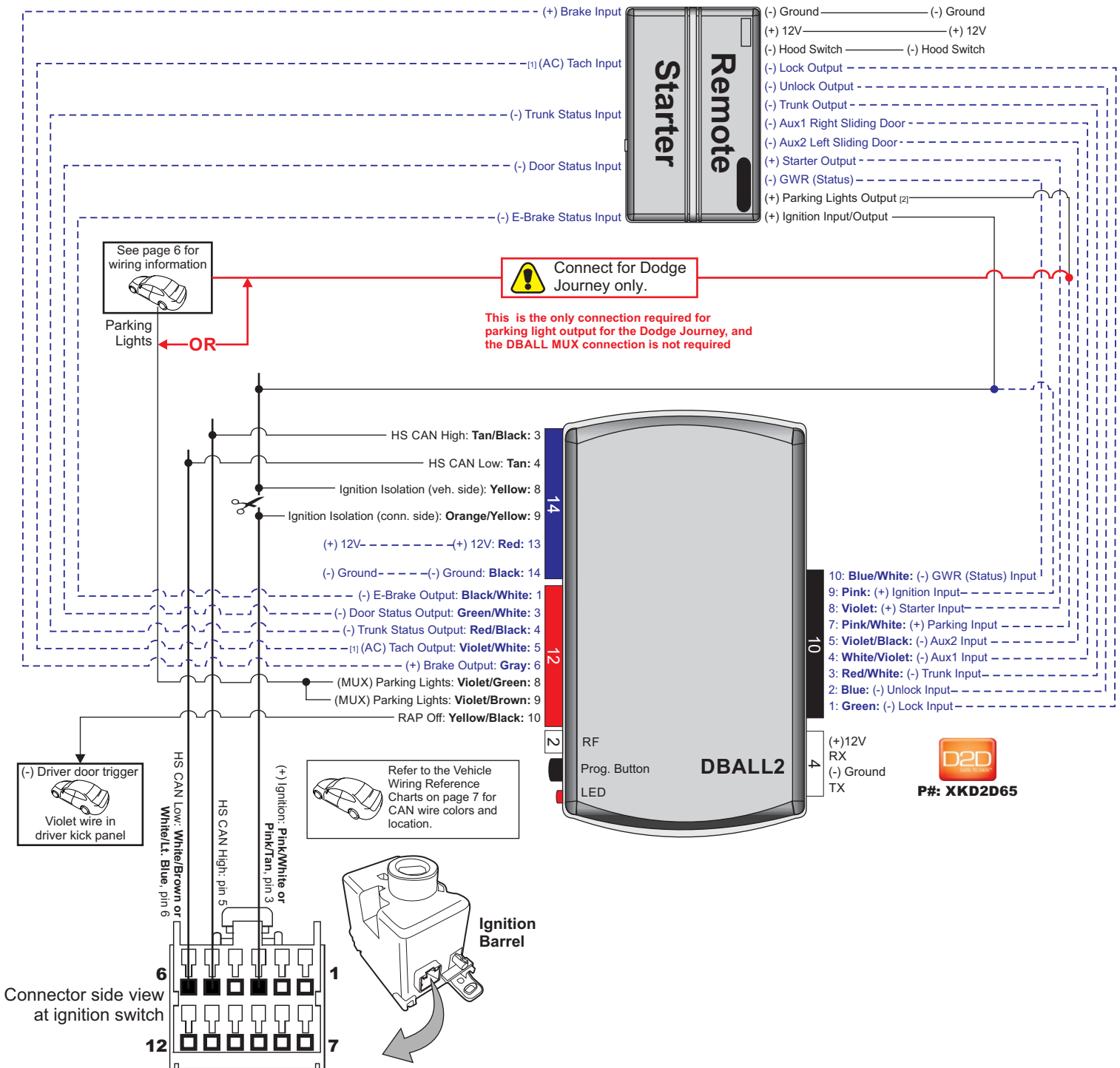

----- Not required in D2D mode.

[1] Tach wire is an optional connection required on some remote starters, which do not support a tach signal in D2D.

[2] Connection required for Dodge Journey.

⚠️ All adapters are displayed from the wire side (unless specified otherwise).

Parking Light Vehicle Wiring Reference Chart (Type 1)

Town & Country	2008-10	White/Brown	Black connector at light switch, pin 1	MUX	8: Violet/Green: (MUX) Parking Lights 9: Violet/Brown: (MUX) Parking Lights
Dodge/Ram					
1500	2011+	White	Black connector at light switch, pin 1	MUX	8: Violet/Green: (MUX) Parking Lights 9: Violet/Brown: (MUX) Parking Lights
2500	2011+	White	Black connector at light switch, pin 1	MUX	8: Violet/Green: (MUX) Parking Lights 9: Violet/Brown: (MUX) Parking Lights
3500	2011+	White	Black connector at light switch, pin 1	MUX	8: Violet/Green: (MUX) Parking Lights 9: Violet/Brown: (MUX) Parking Lights
C/V	2012-16	White/Lt. Green	Black connector at light switch, pin 3	MUX	8: Violet/Green: (MUX) Parking Lights 9: Violet/Brown: (MUX) Parking Lights
Caravan	2008-10	White/Green	Black connector at light switch, pin 3	MUX	8: Violet/Green: (MUX) Parking Lights 9: Violet/Brown: (MUX) Parking Lights
Challenger	2008+	White/Brown	Black connector at light switch, pin 1	MUX	8: Violet/Green: (MUX) Parking Lights 9: Violet/Brown: (MUX) Parking Lights
Challenger (Smart Key)	2008+	White/Brown	Black connector at light switch, pin 1	MUX	8: Violet/Green: (MUX) Parking Lights 9: Violet/Brown: (MUX) Parking Lights
Durango	2011+	White/Green	Black connector at light switch, pin 3	MUX	8: Violet/Green: (MUX) Parking Lights 9: Violet/Brown: (MUX) Parking Lights
Grand Caravan	2011+	White/Green	Black connector at light switch, pin 3	MUX	8: Violet/Green: (MUX) Parking Lights 9: Violet/Brown: (MUX) Parking Lights
Grand Caravan	2008-10	White/Brown	Black connector at light switch, pin 1	MUX	8: Violet/Green: (MUX) Parking Lights 9: Violet/Brown: (MUX) Parking Lights
Journey	2009-10	White/Violet	Passenger kick panel	(+)	Remote Starter (+) Parking Lights
RAM	2009-10	White	Black connector at light switch, pin 1	MUX	8: Violet/Green: (MUX) Parking Lights 9: Violet/Brown: (MUX) Parking Lights
Jeep					
Grand Cherokee	2011+	White/Green	Black connector at light switch, pin 1	MUX	8: Violet/Green: (MUX) Parking Lights 9: Violet/Brown: (MUX) Parking Lights
Grand Cherokee (Smart Key)	2011+	White/Green	Black connector at light switch, pin 1	MUX	8: Violet/Green: (MUX) Parking Lights 9: Violet/Brown: (MUX) Parking Lights
Volkswagen					
Routan	2011+	White/Green	Black connector at light switch, pin 3	MUX	8: Violet/Green: (MUX) Parking Lights 9: Violet/Brown: (MUX) Parking Lights
Routan	2009-10	White/Brown	Black connector at light switch, pin 1	MUX	8: Violet/Green: (MUX) Parking Lights 9: Violet/Brown: (MUX) Parking Lights

Light switch, black 10-pin plug

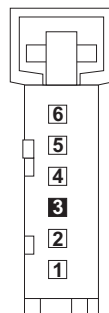
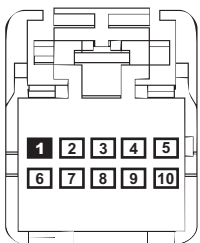

Light switch, black 6-pin plug

CAN Vehicle Wiring Reference Chart (Type 1)

Vehicle	Years	HS CAN High	Pin	HS CAN Low	Pin
Chrysler					
Town & Country	2008+	White/Lt. Blue	5	White/Brown	6
Dodge/Ram					
1500	2011+	White/Lt. Green	5	White/Lt. Blue	6
2500	2011+	White/Lt. Green	5	White/Lt. Blue	6
3500	2011+	White/Lt. Green	5	White/Lt. Blue	6
C/V	2012-2015	White/Lt. Blue	5	White/Brown	6
Caravan	2008-10	White/Lt. Blue	5	White/Brown	6
Challenger	2008+	White/Black	5	White/Lt. blue	6
Challenger (Smartkey)	2008+	White/Black	5	White/Lt. blue	6
Durango	2011+	White/Lt. Blue	5	White/Brown	6
Grand Caravan	2008-11	White/Lt. Blue	5	White/Brown	6
Journey	2009-10	White/Lt. Blue	5	White/Brown	6
RAM	2009-10	White/Lt. Blue	5	White/Brown	6
Jeep					
Grand Cherokee	2011+	White/Lt. Blue	5	White/Brown	6
Grand Cherokee (Smartkey)	2011+	White/Lt. Blue	5	White/Brown	6
Volkswagen					
Routan	2009-2011	White/Lt. Blue	5	White/Brown	6

Installation Type 2a (with CHTHD1/THCHD1 T-Harness R7)

⚠️ Refer to the Vehicle Wiring Reference Charts on page 11 for wire color and location.

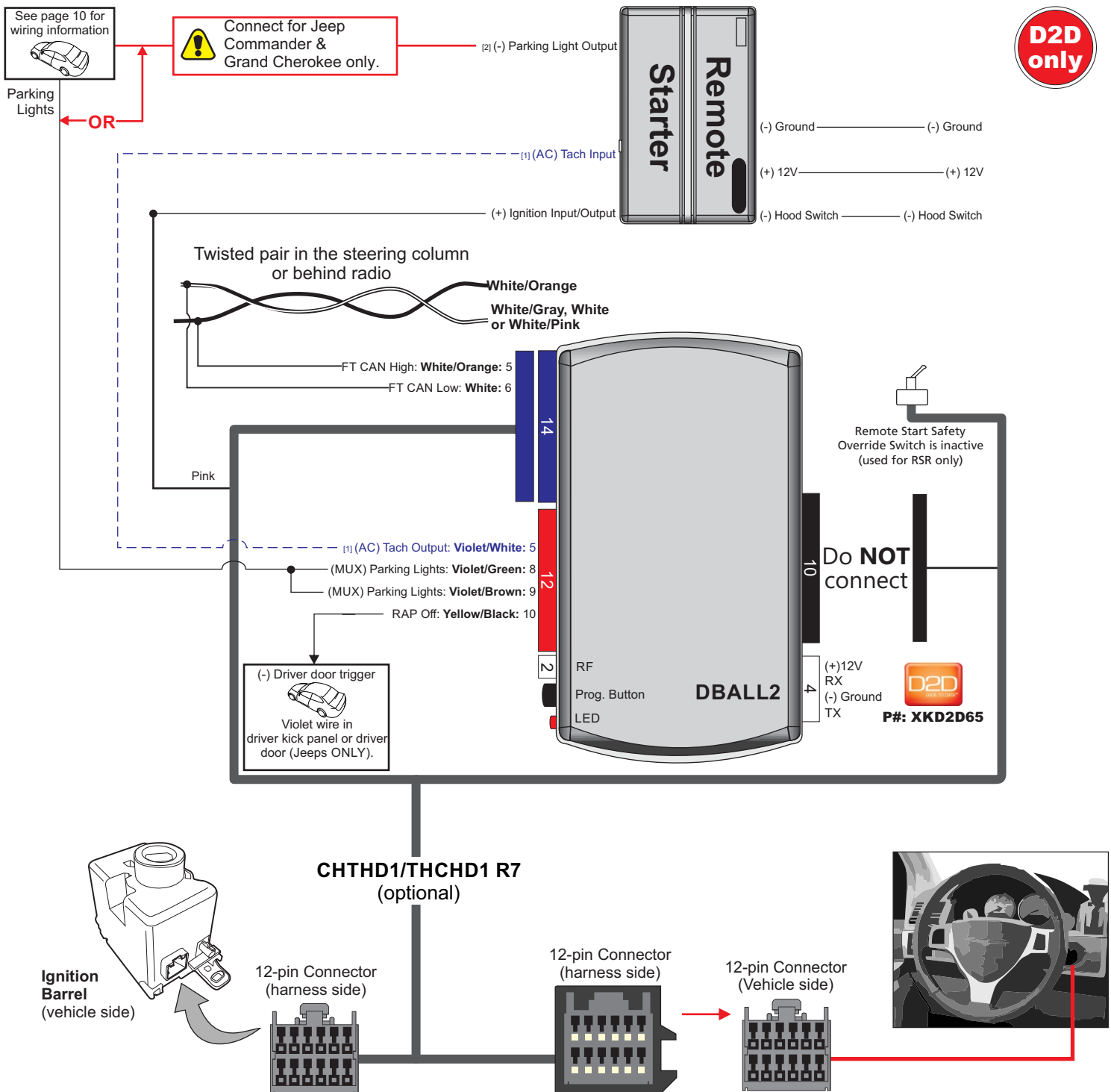

[1] Tach wire is an optional connection required on some remote starters, which do not support a tach signal in D2D.

[2] Connection only required for Jeep Commander & Jeep Grand Cherokee

⚠️ Wires not listed in this diagram are not required for the installation.

⚠️ All adapters are displayed from the wire side (unless specified otherwise).

Installation Type 2b (with CHTHD1/THCHD1 T-Harness R1-R6)

⚠️ Refer to the Vehicle Wiring Reference Charts on page 11 for wire color and location.

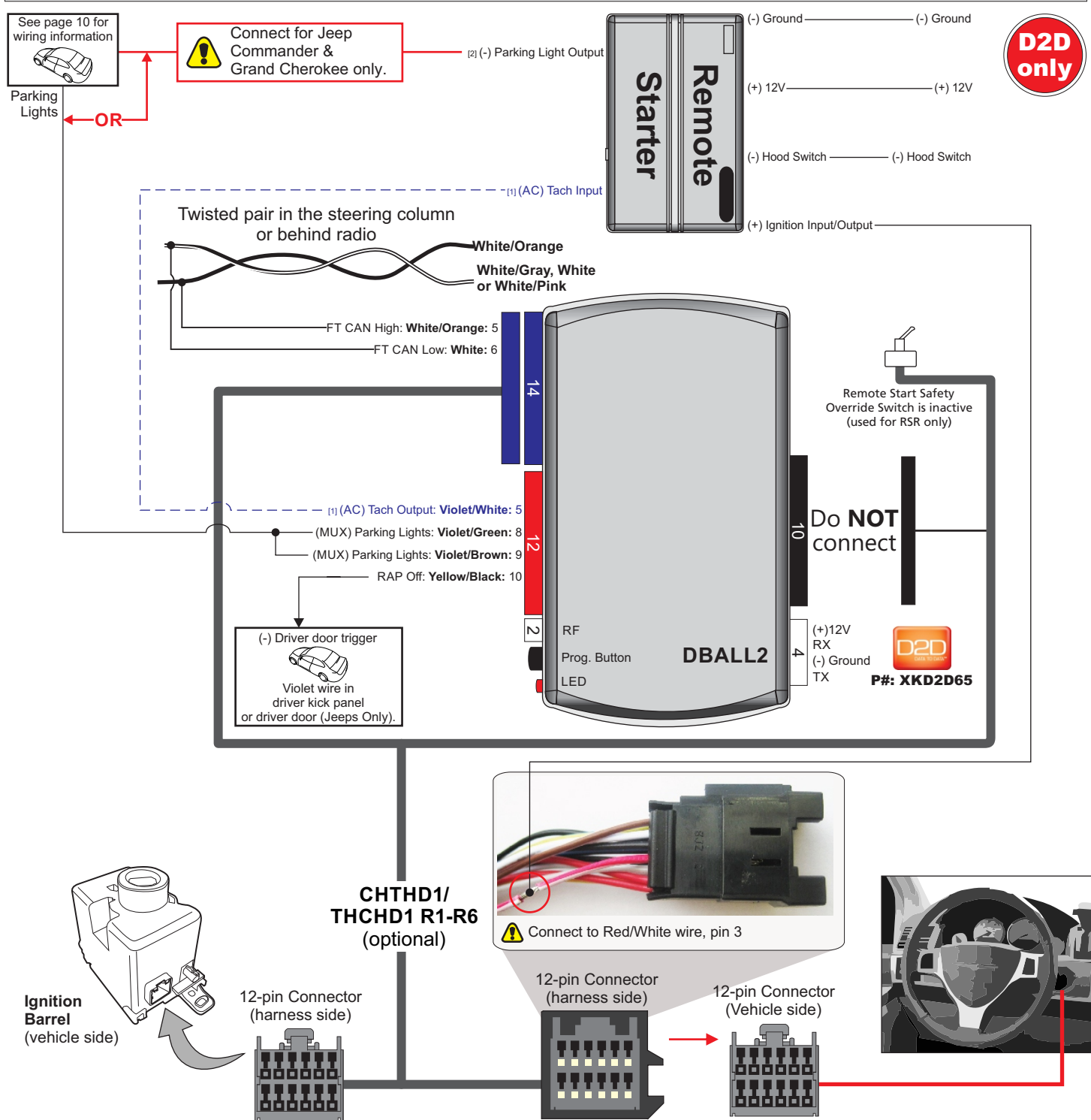

[1] Tach wire is an optional connection required on some remote starters, which do not support a tach signal in D2D.

[2] Connection only required for Jeep Commander & Jeep Grand Cherokee

⚠️ Wires not listed in this diagram are not required for the installation.

⚠️ All adapters are displayed from the wire side (unless specified otherwise).

Installation Type 2c (without T-Harness)

⚠️ Refer to the Vehicle Wiring Reference Charts on page 11 for wire color and location.

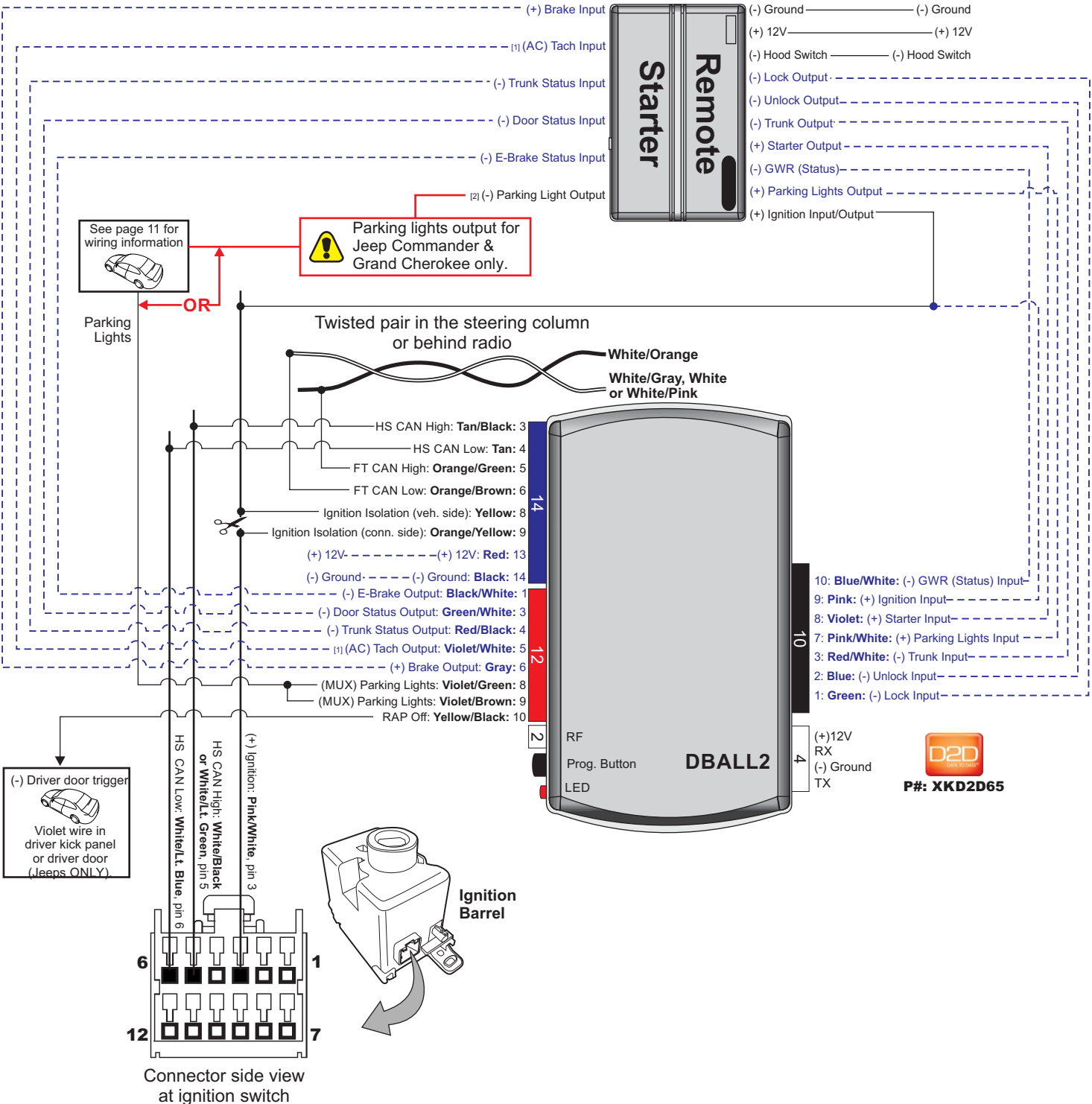

----- Not required in D2D mode.

[1] Tach wire is an optional connection required on some remote starters, which do not support a tach signal in D2D.

[2] Connection only required for Jeep Commander & Jeep Grand Cherokee

⚠️ All adapters are displayed from the wire side (unless specified otherwise).

Parking Light Vehicle Wiring Reference Chart (Type 2)

Vehicle	Years	Vehicle Wire	Location on vehicle	Polarity	DBALL Output from 12 Pin connector
Chrysler					
300/300c	2008-10	White/Brown	Black connector at light switch, pin 1	MUX	8: Violet/Green: (MUX) Parking Lights 9: Violet/Brown: (MUX) Parking Lights
Dodge					
Charger	2008-10	White/Brown	Black connector at light switch, pin 1	MUX	8: Violet/Green: (MUX) Parking Lights 9: Violet/Brown: (MUX) Parking Lights
Magnum	2008	White/Brown	Black connector at light switch, pin 1	MUX	8: Violet/Green: (MUX) Parking Lights 9: Violet/Brown: (MUX) Parking Lights
Jeep					
Commander	2008-10	White/Dk. Blue	Hazard light switch	(-)	(-) Parking Lights Output
Grand Cherokee	2008-10	White/Dk. Blue	Hazard light switch	(-)	(-) Parking Lights Output

Light switch, black 10-pin plug

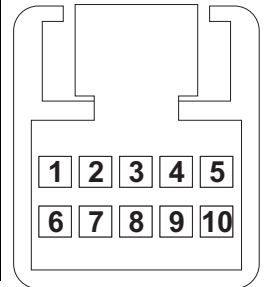

Refer to DirectWire for additional parking light locations.

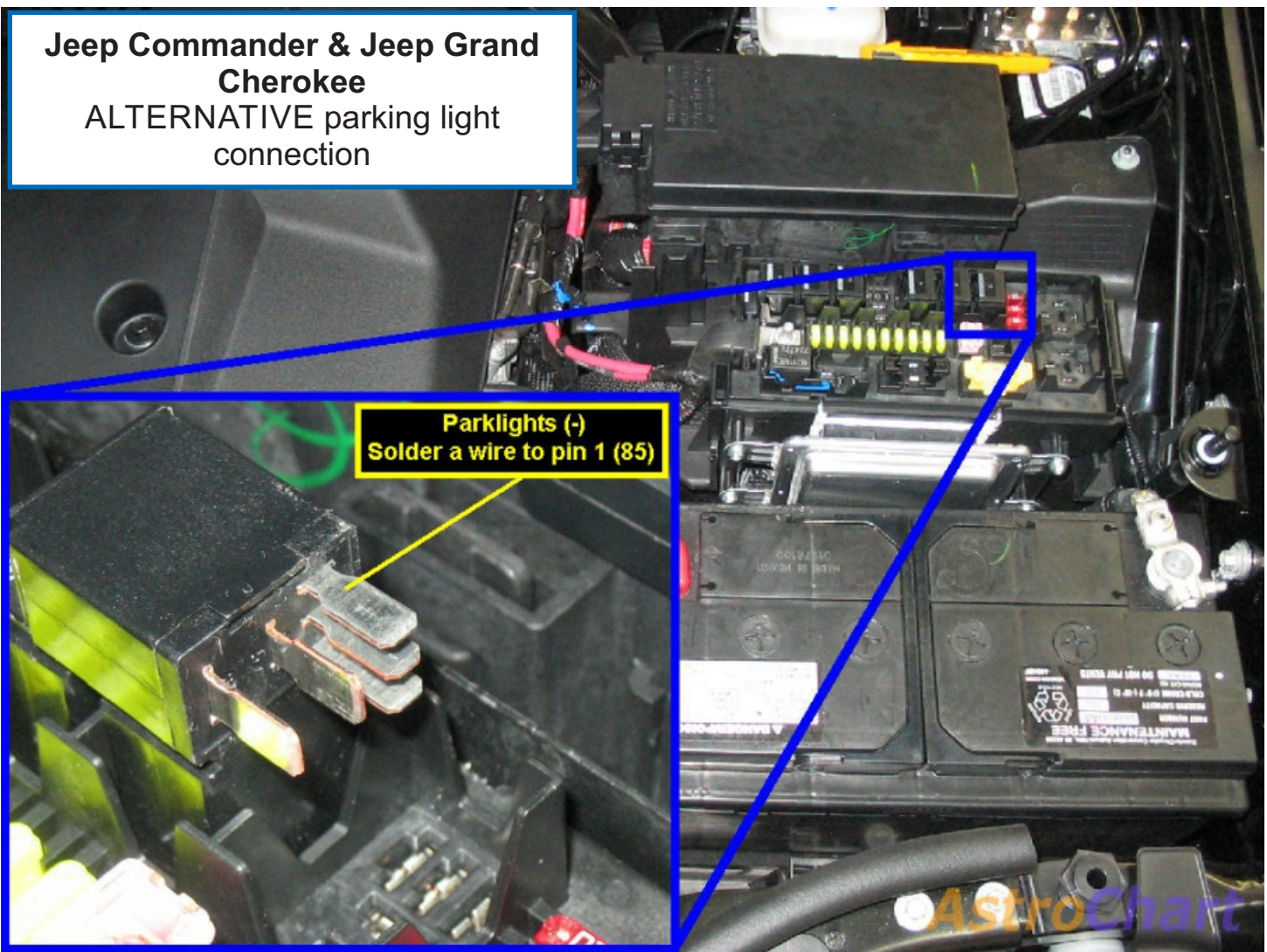

Installation Type 3a (with CHTHD2/THCHD2 T-Harness R9-R10)

⚠️ Refer to the Vehicle Wiring Reference Charts on pages 15-16 for wire color and location.

D2D only

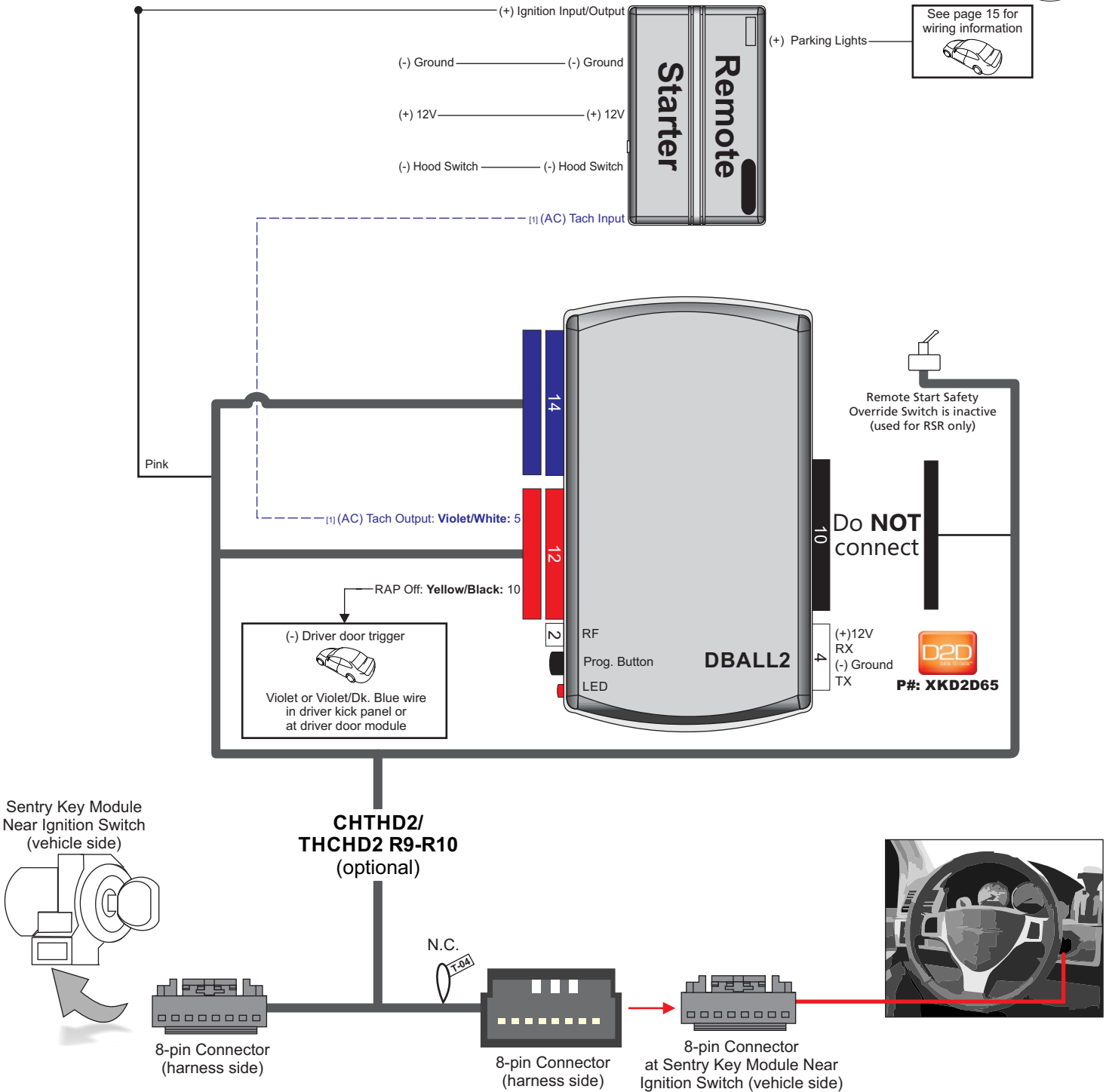

[1] Tach wire is an optional connection required on some remote starters, which do not support a tach signal in D2D.

- ⚠️ Wires not listed in this diagram are not required for the installation.
- ⚠️ All adapters are displayed from the wire side (unless specified otherwise).

Installation Type 3b (with CHTHD2/THCHD2 T-Harness R1-R6)

⚠️ Refer to the Vehicle Wiring Reference Charts on pages 15-16 for wire color and location.

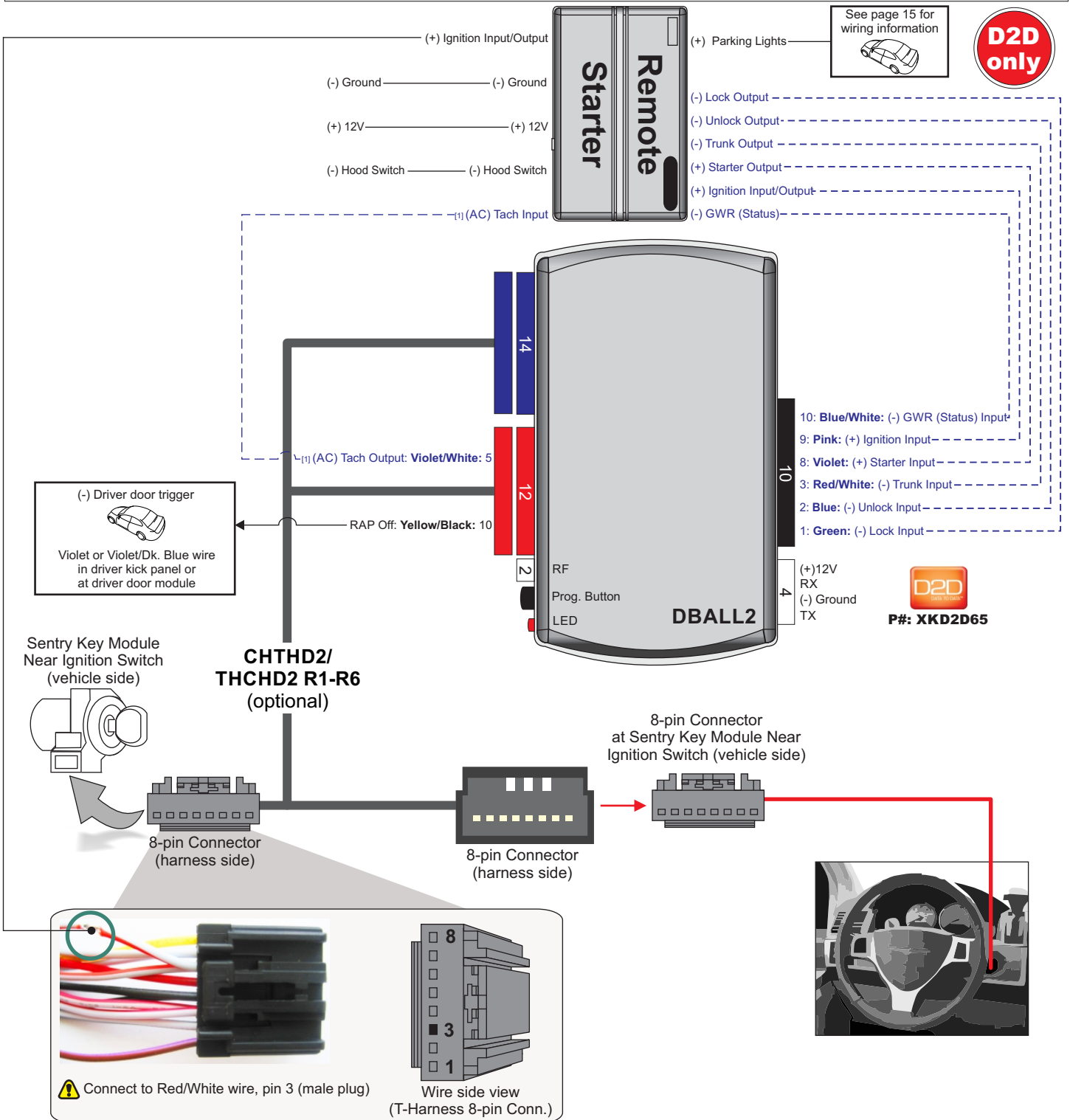

[1] Tach wire is an optional connection required on some remote starters, which do not support a tach signal in D2D.

⚠️ Wires not listed in this diagram are not required for the installation.

⚠️ All adapters are displayed from the wire side (unless specified otherwise).

Installation Type 3c (without T-Harness)

⚠ Refer to the Vehicle Wiring Reference Charts on pages 15-16 for wire color and location.

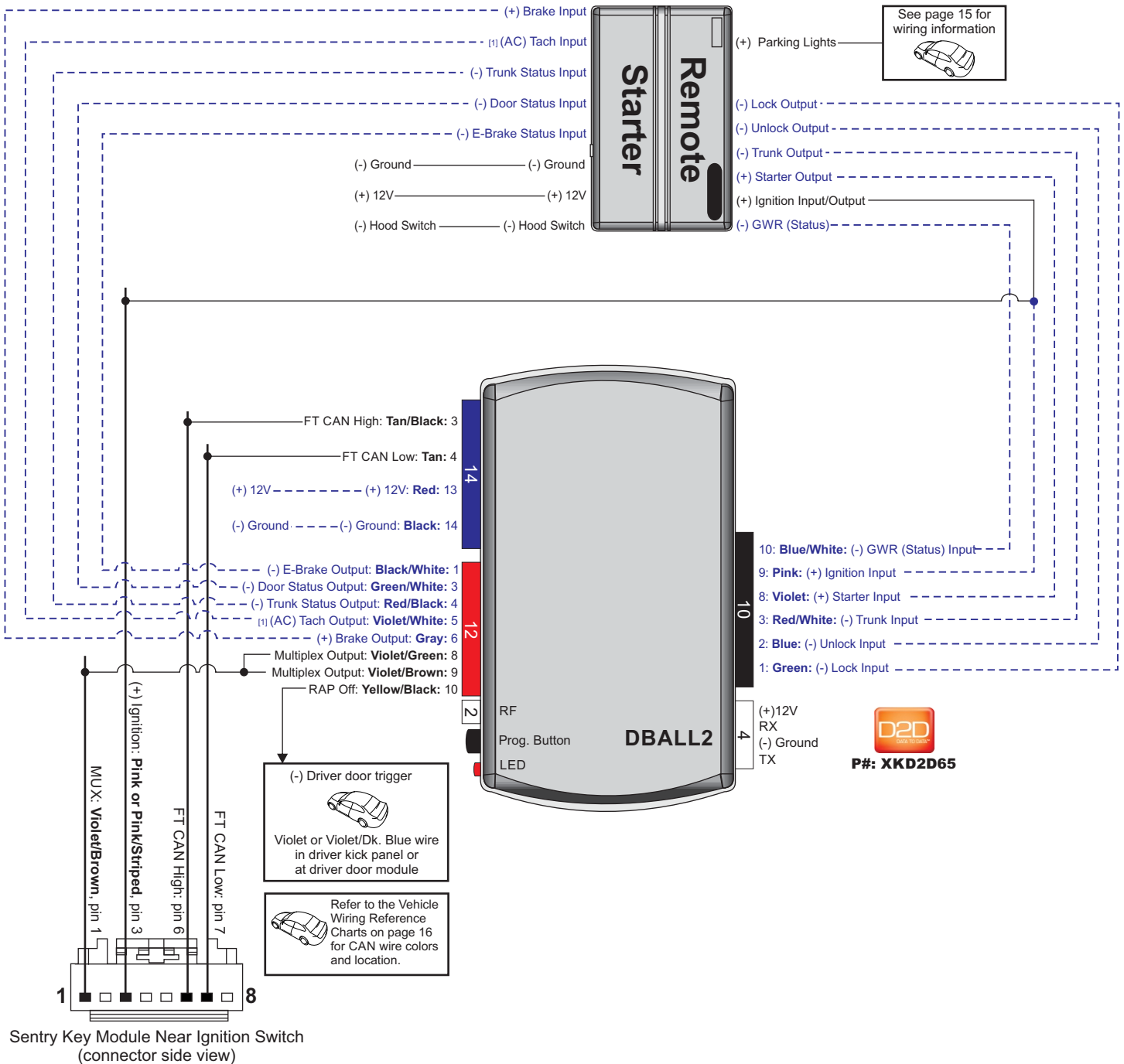

Parking Light Vehicle Wiring Reference Chart (Type 3)

Vehicle	Years	Wire	Polarity	Location
Chrysler				
200	2011-14	White/Violet	(+)	Driver kick panel
Aspen	2007-09	Pink/Red	(+)	Driver kick fuse box, black 40-pin plug
Sebring	2007-10	White/Violet	(+)	Driver kick panel
Sebring Convertible	2008-10	White/Violet	(+)	Driver kick panel
Sebring Sedan	2007-10	White/Violet	(+)	Driver kick panel
Dodge				
Avenger	2008+	White/Violet	(+)	Driver kick panel
Caliber	2007-12	White/Violet	(+)	Driver kick panel
Dakota	2007-11	Pink/Red	(+)	Underhood fuse box, black 20-pin plug, pin 15
Durango	2007-09	Pink/Red	(+)	Driver kick fuse box, black 40-pin plug, pin 6
Nitro	2007-11	White/Violet	(+)	Driver kick panel
RAM	2006-08	White/Yellow (L), White/Gray	(+)	Totally Integrated Power Module under hood, connector C9 pin 8, 10 Use (2) 6 Amp diodes to isolate left and right parking lights.
		OR White/Lt.Green	MUX	Headlight switch. Use a resistor and relay, see Tech Tip 1082 Multiplex Light Circuit Integration.
Jeep				
Compass	2007+	White/Violet	(+)	Driver kick panel
Liberty	2008-12	White/Violet	(+)	Driver kick panel
Patriot	2007+	White/Violet	(+)	Driver kick panel
Wrangler	2007+	White/Violet	(+)	Passenger kick panel
Wrangler Limited	2007+	White/Violet	(+)	Passenger kick panel

Driver kick fuse box,
black 40-pin plug

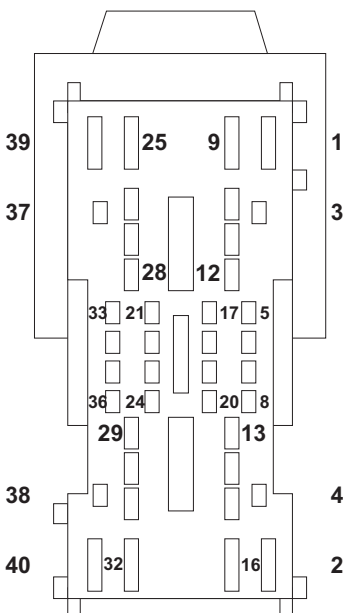

Underhood fuse box, black 20-pin plug

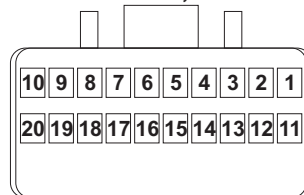

Module-Totally Integrated Power C9

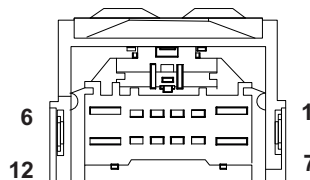

Above driver kick,
gray 74-pin plug

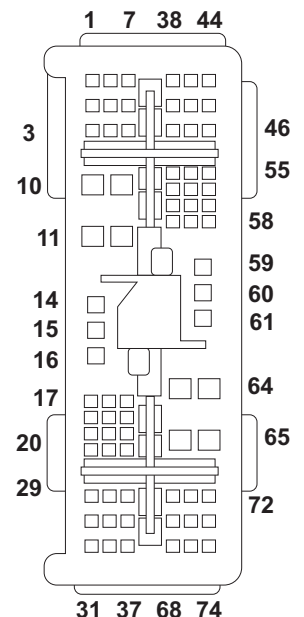

CAN Vehicle Wiring Reference Chart (Type 3)

Vehicle	Years	FT CAN High	FT CAN Low
Chrysler			
200	2011-14	White/Orange	White
Aspen	2007-09	White/Orange	White
Sebring	2007-10	White/Orange	White
Sebring Convertible	2007-10	White/Orange	White
Sebring Sedan	2007-10	White/Orange	White
Dodge/Ram			
Avenger	2008-14	White/Orange	White
Caliber	2007-12	White/Orange	White/Pink
Dakota	2007-11	White/Orange	White
Durango	2007-09	White/Orange	White
Nitro	2007-11	White/Black or White/Lt.Green	White/Lt.Blue
RAM	2006-08	White/Orange	White
Jeep			
Compass	2007-16	White/Orange	White/Pink
Liberty	2008-12	White/Black	White/Lt.Blue
Patriot	2007-16	White/Orange	White/Pink
Wrangler	2007-16	White/Black	White/Lt.Blue
Mitsubishi			
Raider	2007-09	White/Orange	White

Installation Type 4

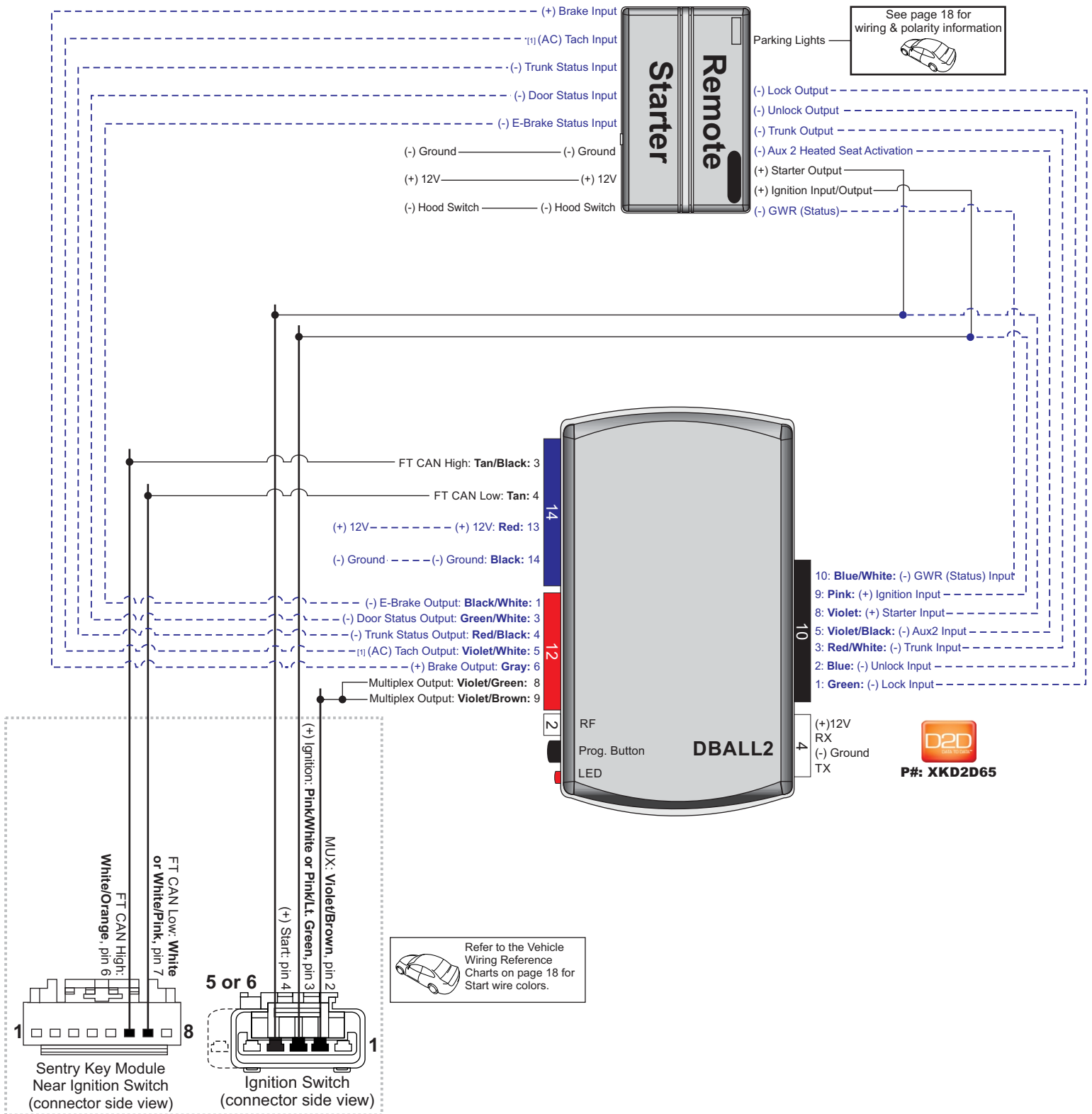

----- Not required in D2D mode.

[1] Tach wire is an optional connection required on some remote starters, which do not support a tach signal in D2D.

All adapters are displayed from the wire side (unless specified otherwise).

Parking Light Vehicle Wiring Reference Chart (Type 4)

Vehicle	Years	Wire	Polarity	Location
Chrysler				
300/300c	2005-07	White/Violet	(+)	Passenger kick panel
PT Cruiser	2006-10	White/Violet	(+)	Driver kick panel
Dodge				
Caliber	2007	White/Violet	(+)	Driver kick panel
Charger	2006-07	White/Violet	(+)	Passenger kick panel
Magnum	2005-07	White/Violet	(+)	Passenger kick panel
RAM	2006	White/Gray	(+)	Above driver kick, gray 74-pin plug, pin 19
Jeep				
Commander	2006-07	White/Dk. Blue	(-)	Hazard light switch
Grand Cherokee	2005-07	White/Dk. Blue	(-)	Hazard light switch

Above driver kick,
 gray 74-pin plug

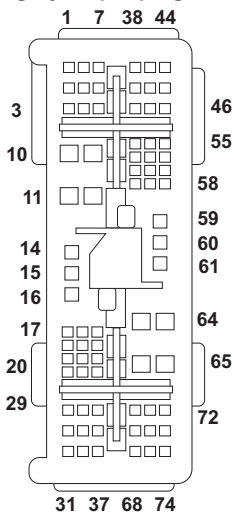

Start - Vehicle Wiring Reference Chart (Type 4)

Vehicle	Years	Wire	Polarity	Location
Chrysler				
300/300c	2005-07	Pink/Dk. Green	(+)	At ignition switch, black 5-pin plug
PT Cruiser	2006-10	Pink/Lt.Blue	(+)	At Ignition harness
Dodge				
Caliber	2007	Pink/Lt.Blue	(+)	At ignition switch, black 5-pin plug
Charger	2006-07	Pink/Dk. Green	(+)	At ignition switch, black 5-pin plug
Magnum	2005-07	Pink/Dk. Green	(+)	At ignition switch, black 5-pin plug
RAM	2006	Dk. Green/Yellow	(+)	At ignition harness or starter button (SRT-10)
Jeep				
Commander	2006-07	Pink/Orange	(+)	At Ignition harness
Grand Cherokee	2005-07	Pink/Orange	(+)	At Ignition harness

Installation Type 5

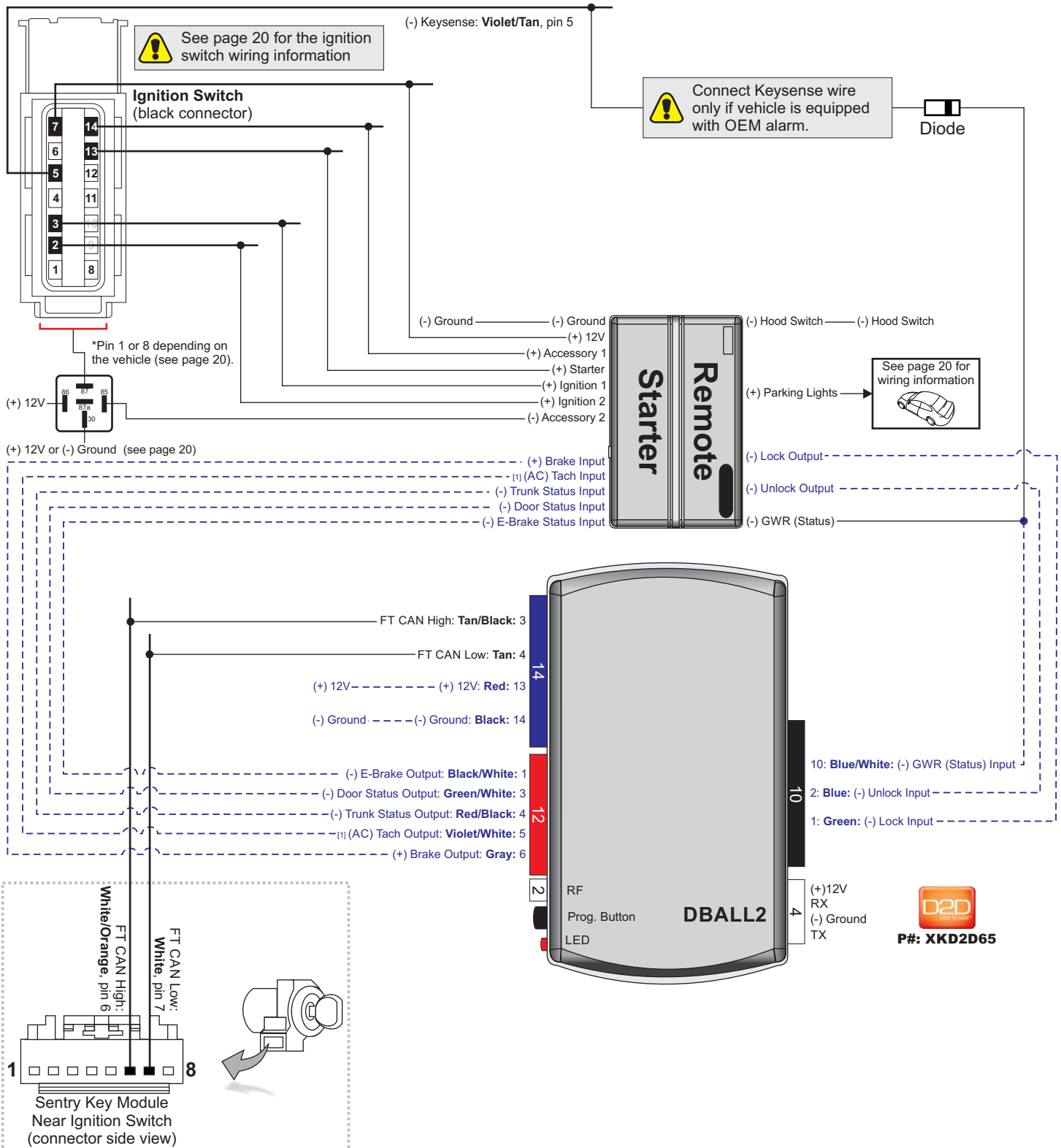

[1] Tach wire is an optional connection required on some remote starters, which do not support a tach signal in D2D.

⚠ All adapters are displayed from the wire side (unless specified otherwise).

Vehicle Wiring Reference Chart (Type 5)

* Vehicle may not have an Accessory 2 wire in pin 1 or 8. If that is the case, this connection is unnecessary.

Vehicle	Years	Parking Lights			12 V	Starter	Ignition	Ignition 2	Accessory	Accessory 2*
		Wire	Polarity	Location						
Dodge										
Dakota	2005	Pink/Red	(+)	Underhood fuse box, black 20-pin plug, pin 15	Red, pin 7	Pink/Lt. Blue, pin 13	Pink/Lt. Green, pin 3	Pink, pin 2	Pink/White, pin 14	Dk. Blue (+), pin 8
Dakota	2006	Pink/Red	(+)	Underhood fuse box, black 20-pin plug, pin 15	Red, pin 7	Pink/Lt. Blue, pin 13	Pink/Lt. Green, pin 3	Pink, pin 2	Pink/White, pin 14	Violet (-), pin 1
Durango	2004	Pink/Red	(+)	Driver kick fuse box, black 40-pin plug, pin 6	Red/Dk. Blue, pin 7	Pink/Lt. Blue, pin 13	Pink/Lt. Green, pin 3	Pink, pin 2	Pink/Yellow, pin 14	Dk. Blue (+), pin 8
Durango	2005-06	Pink/Red	(+)	Driver kick fuse box, black 40-pin plug, pin 6	Red/Dk. Blue, pin 7	Pink/Lt. Blue, pin 13	Pink/Lt. Green, pin 3	Pink, pin 2	Pink/Yellow, pin 14	Violet (-), pin 1
Mitsubishi										
Raider	2006	Pink/Red	(+)	Underhood fuse box, black 20-pin plug, pin 15	Red, pin 7	Pink/Lt. Blue, pin 13	Pink/Lt. Green, pin 3	Pink, pin 2	Pink/White, pin 14	Violet (-), pin 1

Underhood fuse box, black 20-pin plug

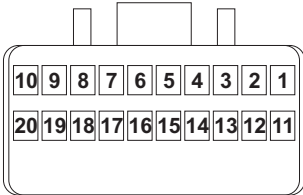

Driver kick fuse box, black 40-pin plug

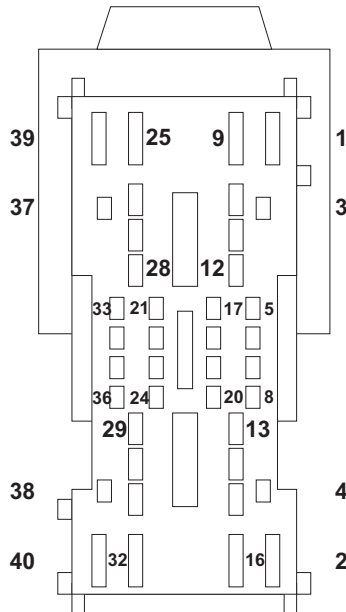

Ignition switch, black 14-pin plug

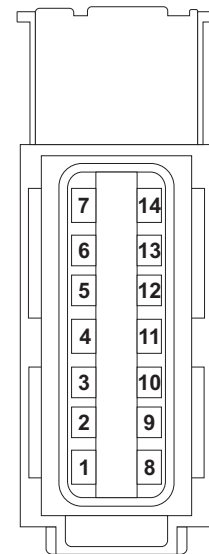

Module Programming

 Refer to the LED Diagnostics section on page 26 for more information and for troubleshooting purposes.

Important

Make all the required connections to the vehicle, as described in the wiring diagram(s) found in this guide, and double check to ensure everything is correct prior to moving onto the next step.

 **Warning!** To take advantage of advanced features, you must use XpressVIP 4.5 (and higher) or the Directechs Mobile app.

Flashing a module using your computer:

1. Connect the interface module to your computer using the XKLoader2.
2. Go to www.directechs.com using Internet Explorer, and select the **Flash Module** button.
3. Follow the instructions to select your vehicle, installation type, and configure your options.
4. Once you have configured the firmware options, click on the **FLASH** button.

Flashing a module using your smartphone or tablet

1. Connect the interface module to your XKLoader3.
2. Launch the Directechs Mobile app on your smartphone or tablet.
3. Select **FLASH YOUR MODULE** and follow the on screen instructions.

When the flashing operation is successful, you can proceed with the programming instructions below.

D2D Installation

If required for your installation, connect the 10-pin, 12-pin and 14-pin harnesses to the module, then connect the 4-pin D2D harness.

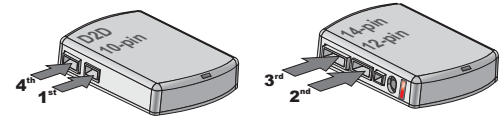

OR

W2W Installation

If required for your installation, connect the 10-pin and 12-pin harnesses to the module, then connect the 14-pin harness to the module.

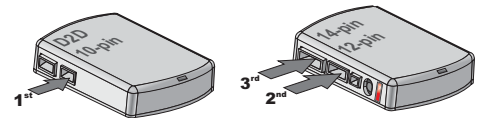

Vehicles WITH Factory Keyless

(Refer to the next page for programming instructions WITHOUT factory keyless.)

- 1 Wait until the LED turns ON solid red.



Solid

- 2 **Key Ignition**

Insert the key into the ignition barrel and turn it to the ON position.

It is important to wait for the LED to start flashing green. Refer to the LED Diagnostics section on page 25 for troubleshooting if the LED does not flash green within 15 seconds.



or **Push-to-Start (PTS) Ignition**

Important: Do NOT press the brake pedal.



Press the Push-to-Start (PTS) button twice to turn the ignition ON.





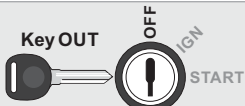

It is important to wait for the LED to start flashing green. Refer to the LED Diagnostics section on page 25 for troubleshooting if the LED does not flash green within 15 seconds.



Go to the next page to complete the module programming. 

3 Turn the key to the OFF position and remove it from the ignition barrel.  **or** Press the Push-to-Start (PTS) button once more to turn the ignition OFF. **1X** 



4 Press LOCK or UNLOCK on the **factory transmitter**. The LED turns ON solid green OR orange for 3 seconds and then turns off.   **&**  **or**  **&** 

You have successfully completed the module programming sequence.



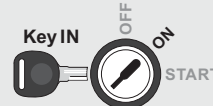

Vehicles WITHOUT Factory Keyless

(Refer to the previous page for programming instructions WITH factory keyless.)

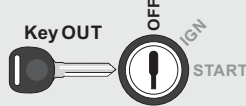
1 Wait until the LED turns ON solid red.  **Solid**

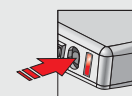
2 Insert the key into the ignition barrel and turn it to the ON position. It is important to wait for the LED to start flashing green.*
 * Refer to the LED Diagnostics section on page 25 for troubleshooting if the LED does not flash green within 15 seconds.  **&**  **Flash Green**

3 Turn the key to the OFF position and remove it from the ignition barrel. 

4 Press and release the Programming Button. The LED turns ON solid green OR orange for 3 seconds and then turns OFF.  **&**  **or**  **&** 

You have successfully completed the module programming sequence.

Module Reset

A module reset will erase the module programming **only** (bypass, convenience and vehicle detection). All the settings configured on the module using the web config tool will remain untouched.

D2D Installation

If required for your installation, connect the 10-pin, 12-pin & 14-pin harnesses to the module. Press and hold the programming button, then connect the 4-pin D2D harness.

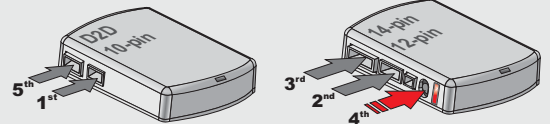

1 OR

W2W Installation

If required for your installation, connect the 10-pin & 12-pin harnesses to the module. Press and hold the programming button, then connect the 14-pin harness to the module.

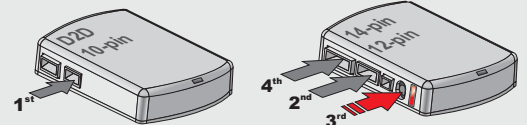

2

Wait 3 seconds until the LED turns ON solid orange then release the programming button. The LED then turns ON solid red.



Hard Reset

Warning Against Executing a Hard Reset!

A hard reset will revert the flashed firmware back to its default settings. Depending on the installation, some settings (such as RFTD and D2D options) may have to be reconfigured. See the **Feature & Option List** section of this guide.

D2D Installation

If required for your installation, connect the 10-pin, 12-pin & 14-pin harnesses to the module. Press and hold the programming button, then connect the 4-pin D2D harness.

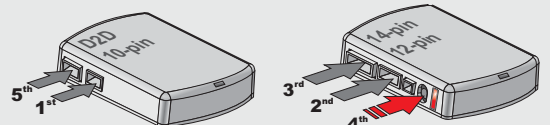

1 OR

W2W Installation

If required for your installation, connect the 10-pin & 12-pin harnesses to the module. Press and hold the programming button, then connect the 14-pin harness to the module.

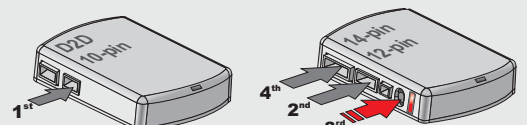

2

Wait 3 seconds until the LED turns ON solid orange, and wait 10 more seconds until the LED starts to flash orange and red.



3

Release the programming button. The LED turns ON solid red.



Feature & Option List

It is recommended to configure all the features and options listed below using the configuration tool found on the module flashing page on www.directechs.com. The web offers more options; however, manual configuration of the features is possible using the information on this page.

* Default option

Feature	Operation	Flashes / Option	Description
1	RF Output Type	1. Disabled*	Module is connected to a remote starter using a standard installation.
		2. RFTD Output	Module is connected to an XL202 using an RSR or RXT installation (when available).
		3. SmartStart	Module is connected to SmartStart using an RSR or RXT installation (when available).
2	Unlock Driver Priority	1. Driver Priority*	Unlocks only the driver door on first press and unlocks all doors on a second press within 5 seconds.
		2. All	Unlocks all doors on first press.
3	Trunk	1. Trunk*	Will pop the trunk if available.
		2. Right Sliding Door	When available, will operate the right sliding door.
		3. Left Sliding Door	When available, will operate the left sliding door.
4	Aux1	1. Trunk	Trunk: Will pop the trunk if available.
		2. Right Sliding Door*	When available, will operate the right sliding door.
		3. Left Sliding Door	When available, will operate the left sliding door.
5	Aux2	1. Disabled	3./4. Right/Left Sliding Door: When available, will operate the sliding door.
		1. Trunk	Will pop the trunk if available.
		2. Right Sliding Door	When available, will operate the right sliding door.
6	Heated Seats	1. Disabled*	No operation.
		2. Enabled	If available, it will activate the Heated Seats Control feature (see feature #7)
		1. 32° Fahrenheit (0° Celsius)*	When feature #6 (Heated Seats) is enabled, it will activate the heated seats upon remote start when temperature is below 32 °F (0 °C).
7	Heated Seats/Defrost Temperature Control (Feature 6 must be enabled) Note: If the Heated Seats feature is activated, it can always be turned on using the Aux2 command, regardless of the temperature setting.	2. 23° Fahrenheit (-5° Celsius)	When feature #6 (Heated Seats) is enabled, it will activate the heated seats upon remote start when temperature is below 23 °F (-5 °C).
		3. 41° Fahrenheit (5° Celsius)	When feature #6 (Heated Seats) is enabled, it will activate the heated seats upon remote start when temperature is below 41 °F (5 °C).
		4. Always ON	When feature #6 (Heated Seats) is enabled, it will activate the heated seats at any temperature.
		1. High*	When Heated Seats are activated, they will be set to HIGH.
8	Heated Seats Temperature Level (Feature 6 must be enabled)	2. Low	When Heated Seats are activated, they will be set to LOW.
		1. Disabled	The OEM alarm will not be controlled by DBALL upon remote start. No disarm or arm command will be executed at the beginning or end of the sequence; it must be controlled by the Remote Starter.
9	Smart OEM Alarm Control	2. Safelock	Smart OEM Alarm Control will behave like a standard Safelock feature on a remote starter. It will unlock at the beginning of the sequence, and relock after start and shutdown.
		3. Enabled*	Smart OEM Alarm Control will synchronize with the OEM alarm so that it will disarm and rearm the vehicle in the remote start sequence, only when required. The reason for this is, factory alarm control must often be done by lock or unlock operation. This could create unnecessary actions on door lock modules, such as the horn to honk. When possible, Smart OEM Alarm Control will monitor the alarm and door lock status to detect if the disarm or rearm is required. If the vehicle is unlocked or is not equipped with factory alarm, the disarm/rearm will not be executed. Smart OEM Alarm Control will also monitor the remote starter actions so that the factory alarm control is not done twice. A remote starter, for which the Safelock feature is active, will work perfectly with this option and will make it invisible to the user.

Feature Programming

Programming
Button

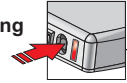

To enter feature programming routine

- Turn the ignition ON, then OFF.
- **Within 5 seconds**, press and HOLD the programming button until the LED turns ON orange (after 3 seconds). Release the Programming button.
- The LED will flash green once slowly to indicate the feature number is 1. After a short delay, the LED flashes red rapidly to indicate the current option of feature 1 (i.e. 1x green followed by 1x red indicates feature 1 is set to option 1). The flashing sequence will repeat until a new command is entered.

Changing feature options

- Press the lock/arm or unlock/disarm button on aftermarket transmitter to change the option of the selected feature.
- The LED flashes red rapidly the number of times equal to the current option number. After a short delay, the LED flashes green slowly the number of times to indicate the current feature. The flashing sequence will repeat until a new command is entered.

Accessing another feature

- Press and release the programming button a number of times to advance from the current feature to the next desired feature.
- The LED flashes green slowly the number of times equal to the feature number. After a short delay, the LED flashes red rapidly to indicate the current option of the current feature. The flashing sequence will repeat until a new command is entered.

When the maximum number of features or options is reached, the LED will start flashing again from the first feature or option.















Once a feature is programmed

- Other features can be programmed.
- The feature programming can be exited.

Exiting feature programming

- No activity for 30 seconds; after 30 seconds, the LED will turn ON orange for 2 seconds to confirm the end of the programming sequence.
OR
- Press and HOLD the programming button for 3 seconds. After 3 seconds, the LED will turn ON orange for 2 seconds to confirm the end of the programming sequence.

LED Diagnostics & Troubleshooting

LED	Description	Troubleshooting
Module Programming		
 Off	Module has no power.	Check the power connections.
 Solid red	The bus type cannot be detected.	Make sure the connections to the data bus are correct and insert the key in the ignition switch.
 Flashes orange	The vehicle type cannot be detected.	Insert the key in the ignition switch and turn to the ON position. You may need to wait up to 10 seconds.
 Flashes green	Waiting for keyless.	Remove the key from the ignition switch and press a keyless button.
 Solid green x3 secs	Module was successfully programmed or is already programmed.	Normal operation.
 Solid orange x3 secs	Module was successfully programmed without diagnostics.	Normal operation.
Active Ground While Running		
 Flashes green	GROUND OUT ON (GWR) command received.	Otherwise, the Ground While Running (status) signal was lost or was never received by the module. Commands can come from RF, D2D or W2W.
 Flashes red & orange	IGNITION ON command received.	Otherwise, the ignition signal was not received by the module. In a W2W install, it will show only if the ignition input wire is used.
 Flashes green quickly	START ON command received.	Otherwise, the start signal was not received by the module. In a W2W install, it will show only if the ignition input wire is used.
External Module Synchronization		
 (Flashes red, then orange) x 10	OBDII feature not supported. Diagnostic data bus not detected.	Some features are not supported by SmartStart. This can be caused by missing wire connections or module hardware limitation. Refer to the wiring installation section to check the connections.
D2D and W2W Commands		
 Flashes orange x1	LOCK command has been received	Normal operation.
 Flashes orange x2	UNLOCK command has been received	
 Flashes orange x3	TRUNK command has been received	
 Flashes orange x4	AUX1 command has been received	
 Flashes orange x5	AUX2 command has been received	

Limited One Year Consumer Warranty

For a period of ONE YEAR from the date of purchase of a Directed Electronics remote start or security product, Directed Electronics. ("DIRECTED") promises to the original purchaser, to repair or replace with a comparable reconditioned piece, the security or remote start accessory piece (hereinafter the "Part"), which proves to be defective in workmanship or material under normal use, provided the following conditions are met: the Part was purchased from an authorized DIRECTED dealer; and the Part is returned to DIRECTED, postage prepaid, along with a clear, legible copy of the receipt or bill of sale bearing the following information: consumer's name, address, telephone number, the authorized licensed dealer's name and complete product and Part description.

This warranty is nontransferable and is automatically void if the Part has been modified or used in a manner contrary to its intended purpose or the Part has been damaged by accident, unreasonable use, neglect, improper service, installation or other causes not arising out of defect in materials or construction.

TO THE MAXIMUM EXTENT ALLOWED BY LAW, EXCEPT AS STATED ABOVE, ALL WARRANTIES, INCLUDING BUT NOT LIMITED TO EXPRESS WARRANTY, IMPLIED WARRANTY, WARRANTY OF MERCHANTABILITY, FITNESS FOR PARTICULAR PURPOSE AND WARRANTY OF NONINFRINGEMENT OF INTELLECTUAL PROPERTY, ARE EXPRESSLY EXCLUDED; AND DIRECTED NEITHER ASSUMES NOR AUTHORIZES ANY PERSON OR ENTITY TO ASSUME FOR IT ANY DUTY, OBLIGATION OR LIABILITY IN CONNECTION WITH ITS PRODUCTS. DIRECTED HEREBY DISCLAIMS AND HAS ABSOLUTELY NO LIABILITY FOR ANY AND ALL ACTS OF THIRD PARTIES INCLUDING DEALERS OR INSTALLERS. DIRECTED IS NOT OFFERING A GUARANTEE OR INSURANCE AGAINST VANDALISM, DAMAGE, OR THEFT OF THE AUTOMOBILE, ITS PARTS OR CONTENTS, AND DIRECTED HEREBY DISCLAIMS ANY LIABILITY WHATSOEVER, INCLUDING WITHOUT LIMITATION, LIABILITY FOR THEFT, DAMAGE, OR VANDALISM. IN THE EVENT OF A CLAIM OR A DISPUTE INVOLVING DIRECTED OR ITS SUBSIDIARY, THE PROPER VENUE SHALL BE SAN DIEGO COUNTY IN THE STATE OF CALIFORNIA. CALIFORNIA STATE LAWS AND APPLICABLE FEDERAL LAWS SHALL APPLY AND GOVERN THE DISPUTE. THE MAXIMUM RECOVERY UNDER ANY CLAIM AGAINST DIRECTED SHALL BE STRICTLY LIMITED TO THE AUTHORIZED DIRECTED DEALER'S PURCHASE PRICE OF THE PART. DIRECTED SHALL NOT BE RESPONSIBLE FOR ANY DAMAGES WHATSOEVER, INCLUDING BUT NOT LIMITED TO, ANY CONSEQUENTIAL DAMAGES, INCIDENTAL DAMAGES, DAMAGES FOR THE LOSS OF TIME, LOSS OF EARNINGS, COMMERCIAL LOSS, LOSS OF ECONOMIC OPPORTUNITY AND THE LIKE. NOTWITHSTANDING THE ABOVE, THE MANUFACTURER DOES OFFER A LIMITED WARRANTY TO REPLACE OR REPAIR AT DIRECTED'S OPTION THE PART AS DESCRIBED ABOVE.

This warranty only covers Parts sold within the United States of America and Canada. Parts sold outside of the United States of America or Canada are sold "AS-IS" and shall have NO WARRANTY, express or implied. Some states do not allow limitations on how long an implied warranty will last or the exclusion or limitation of incidental or consequential damages. This warranty gives you specific legal rights and you may also have other rights that vary from State to State. DIRECTED does not and has not authorized any person or entity to create for it any other obligation, promise, duty or obligation in connection with this Part. For further details relating to warranty information of Directed products, please visit the support section of DIRECTED's website at: www.directed.com



920-10012-01 2013-07

This Interface kit / Data Bus Interface part has been tested on the listed vehicles. Other vehicles will be added to the select vehicle list upon completion of compatibility testing. Visit website for latest vehicle application guide. DISCLAIMER: Under no circumstances shall the manufacturer or the distributors of the bypass kit / data bus interface part(s) be held liable for any consequential damages sustained in connection with the part(s) installation. The manufacturer and its distributors will not, nor will they authorize any representative or any other individual to assume obligation or liability in relation to the interface kit / data bus interface part(s) other than its replacement. N.B.: Under no circumstances shall the manufacturer and distributors of this product be liable for consequential damages sustained in connection with this product and neither assumes nor authorizes any representative or other person to assume for it any obligation or liability other than the replacement of this product only.

Protected by U.S. Patents: 5,719,551; 6,011,460 B1 *; 6,243,004 B1; 6,249,216 B1; 6,275,147 B1; 6,297,731 B1; 6,346,876 B1; 6,392,534 B1; 6,529,124 B2; 6,696,927 B2; 6,756,885 B1; 6,756,886 B2; 6,771,167 B1; 6,812,829 B1; 6,924,750 B1; 7,010,402 B1; 7,015,830 B1; 7,031,826 B1; 7,046,126 B1; 7,061,137 B1; 7,068,153 B1; 7,205,679 B1; Cdn. Patent: 2,320,248; 2,414,991; 2,415,011; 2,415,023; 2,415,027; 2,415,038; 2,415,041; 2,420,947; 2,426,670; 2,454,089; European Patent: 1,053,128; Pat. Pending: 2,291,306. Made in Canada.

Vehicle Takeover

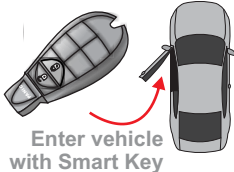

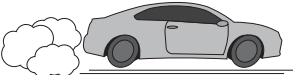
The Vehicle Takeover and Pit Stop Mode with Push-to-Start (PTS) is applicable only to vehicles with a **smart key**.

1	Press the remote start button on the transmitter to start the vehicle.*	 <p>Press remote start button*</p>
2	Enter the vehicle, while making sure the key is inside with you.	 <p>Enter vehicle with Smart Key</p>
3	<p>Important: Do NOT press the brake pedal.</p> <p>Press the PTS button twice to turn the ignition ON.</p>	 <p>Do NOT press brake pedal</p>  <p>2X PUSH</p>
4	Press the brake pedal, put the car in gear and drive off.	<p>Ready to drive off</p> 

* Your remote may differ from the model shown in the illustrations.

Pit Stop Mode

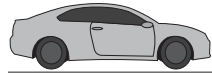
The Pit Stop Mode feature is practical when you need to stop and run an errand, but wish to keep the engine running.

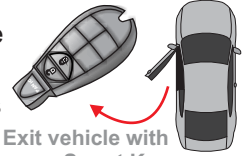
1	Stop the vehicle in a safe parking spot and put the gear in Park (P).	 <p>Stop & put vehicle in Park (P)</p>
2	Press the button to remote start the vehicle.*	 <p>Press remote start button*</p>
3	Press the PTS button once.	 <p>PUSH</p>
4	<p>It is now safe to leave the engine running and exit the vehicle with the Smart Key in hand.</p> <p>Note: We recommend that you always lock the doors of your vehicle when leaving it unattended.</p>	 <p>Exit vehicle with Smart Key</p>

* Your aftermarket remote may differ from the model shown in the illustrations.

Notes
