

BEFORE YOU START!

- * Always Wear Safety Glasses!
- * Use Extra Caution when Working with Electrical Components

High Performance Adjustable RPM Shift Lights

- Part # 67005C Shift Light
- Part # 67005SC Shift Light
- Part # 67005BC Shift Light
- Part # 67005RC Shift Light

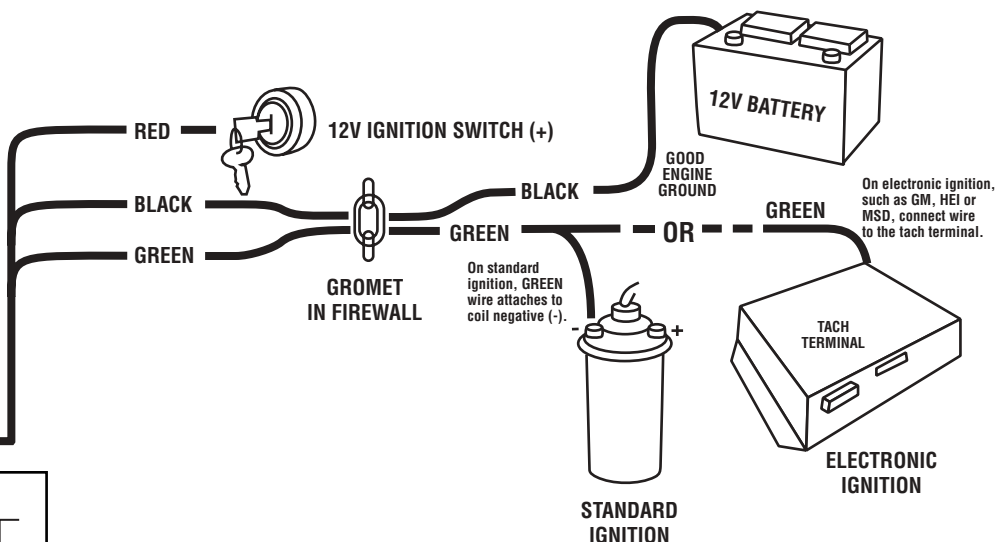
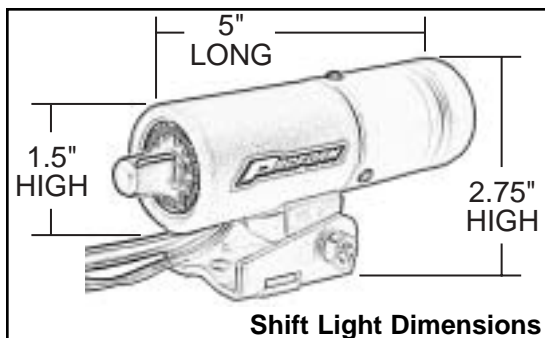

Calibration to Match Your Engine

- 8 CYL. – No adjustment is necessary
 - 6 CYL. – Clip BROWN wire loop only
 - 4 CYL. – Clip BROWN and ORANGE wire loops
- Insulate cut wire with electrical tape!

Mounting

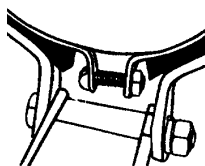

The versatile shift light base design permits many mounting possibilities, using ordinary machine screws. In some cases mounting with a hose clamp may be preferred. This shift light is equipped with a rubber lined shock mounting ring: therefore, proper installation demands that nothing should touch the housing or the mounting ring. Mounting the shift light on the dashboard, where windshield clearance could be a problem, is permitted by the extra length on the mounting bracket.

Troubleshooting

Proper shift light operation requires a good ground and securely connected wiring. If you are having trouble, double-check your ground and be certain that you have 12 volt power. Be sure you have followed the wiring diagram instructions above. We recommend you avoid crimp connectors and solder all connections if possible. Soldering your connections will minimize any loose connections that may cause problems.

LIMITED WARRANTY: Specialty Auto Parts U.S.A., Inc. will, within a reasonable period of time, repair or replace free of charge any part listed in this catalog which upon careful inspection is found, in our sole judgement, to have material or manufacturing defects, provided it is received within thirty (30) days of date of purchase accompanied by a sales slip, the original packaging, and an authorized Return Merchandise Authorization number (RMA). End-users should return the part to the seller from whom they made their purchase. The seller will obtain an RMA by calling (586) 774-2500. To make a warranty claim, the seller must return the part to Specialty Auto Parts U.S.A., Inc., 26708 Groesbeck Highway, Warren, MI 48089, freight prepaid. There is absolutely no warranty for the following conditions: (1) Any parts used on racing applications, (2) Any part that has been physically or mechanically altered, (3) Any part that has been improperly installed or maintained, (4) Any part used in improper applications or not used in conjunction with the proper parts. **There are no implied warranties of merchantability or fitness for a particular purpose.** There are no warranties, which shall extend beyond the warranty description herein. Specialty Auto Parts U.S.A., Inc. will not be responsible for incidental damages, consequential damages, property damages, or personal injury damages to the extent permitted by law. PLEASE NOTE: SOME STATES DO NOT ALLOW LIMITATIONS ON HOW LONG IMPLIED WARRANTIES MAY LAST OR DO NOT ALLOW EXCLUSIONS OR LIMITATIONS OF INCIDENTAL OR CONSEQUENTIAL DAMAGES, SO THOSE EXCLUSIONS OR LIMITATIONS MAY NOT BE APPLICABLE TO YOU. Some of the parts listed in this catalog are not legal for sale or use in California or any pollution controlled vehicles. Installation of proform and proform factory performance parts may adversely affect the warranty coverage on your vehicle. Specialty Auto Parts U.S.A., Inc. assumes no liability for errors made in component selections or installations. Specialty Auto Parts U.S.A., Inc. reserves the right to make necessary changes in products it manufactures and markets at any time to improve product performance. Proform and Factory Performance Parts are registered trademarks of Specialty Auto Parts U.S.A., Inc.

— WARNING —

ATTACH ONLY TO TACH TERMINAL. Warranty will be void if connected to coil on MSD ignitions. You must check with the engine manufacturer for recommended safe shift points PRIOR to setting your shift point on this shift light. Failure to comply with this may lead to over-revving of your engine and may cause serious damage to your engine.

LATE-MODEL INSTALLATION TIPS

This list represents our most common list of application questions as received by our Tech Dept. If you do not find your application below, please visit www.proformparts.com/TECH or call (800) 521-1005 for more information.

GM CARS & TRUCKS

Buick Regal T-Types and Grand Nationals

In looking near the power steering reservoir you should find two white wires with a green plug. Carefully splice the green wire to the green plug.

2.2L/2.4L 1994 and beyond

Connect the green wire to either the white or the white with black wire off the coil pack.

HEI Distributors

Connect the green wire to the C-terminal/wire (usually brown), or to the TAC terminal on the distributor.

GM Dual Connector

Connect the green wire to the white wire off the connector (usually gray) on the coil and distributor.

LT1 Engines

Connect the green wire to white or white with black stripe wire coming off the 32-pin connector (beneath the air cleaner) or coming off the ignition control module (ICM) coil pack.

LS1 Engines 1997 and 1998

Connect the green wire to the white wire coming from pin number 35 in the blue 80 pin connector (found in the engine bay on the passenger side firewall).

LS1 Engines 1999+

In the engine bay on the passenger side firewall find the red connector (furthest from the fenderwell) and connect into pin number 10 which is typically a white wire. For Corvette applications the connector is located underneath the battery and will typically require removing the front tire and some of the fenderwell to access the connector. The 5.3L Silverado truck's connector is located behind the battery on the driver's side fenderwell. Calibrate to the 4 cylinder settings.

FORD CARS & TRUCKS

TFI Distributors

Connect the green wire to the green wire with yellow stripe that is on the coil. NOTE: This wire is occasionally solid green or a green wire with a white stripe.

2.3L, 3.0L, 3.8L, and 4.0L Engines

Connect the green wire to pin number 12 on the DIS module (typically black wire with a yellow stripe).

3.8L and 4.6L Mustangs (1996-1998)

Connect the green wire to pin number 48 (typically an orange wire with white stripe) in the Powertrain Control Module (PCM), a 104 wire connector found behind the passenger side kick panel.

4.2L, 4.6L, and 5.4L F-Series Trucks (1996-1998) and most Super Duty and vans through 1998

Connect the green wire to pin number 48 (typically a white wire with a pink or red stripe) in the Powertrain Control Module (PCM), a 104 wire connector found in the engine bay on the passenger side firewall. We do not recommend using the shift lights or tachometers with Triton V-10 applications.

Ranger Trucks

2.3L 1993-1994, connect the green wire to pin number 4 (typically a tan wire with a yellow stripe) in the Powertrain Control Module (PCM), or connect to pin number 12 (typically a tan wire with a yellow stripe) in the Ignition Control Module (ICM). For the 4.0L engines, use either the PCM connection above, or connect to pin number 2 (typically a tan wire with a yellow stripe) in the ICM. For the 3.0L engines, connect to pin number 4 (typically a white wire with a pink stripe) in the PCM, or connect to pin B (typically a tan wire with a yellow stripe) in the ICM. For 1995+ engine applications, connect to pin number 48 (typically a tan/brown wire with a yellow stripe) in the PCM (found on the passenger side firewall).

CHRYSLER CARS & TRUCKS

Dodge Neons

Connect the green wire to the gray wire with blue stripe coming from the Powertrain Control Module (PCM). The PCM can be found in the engine bay on the driver's side fenderwell between the shock tower and front grill.

SPORT IMPORT APPLICATIONS

Honda and Acura

For early applications, connect the green wire to the blue wire coming from the distributor. On late model applications, connect the green wire to the yellow wire with the green stripe coming from the Ignition Control Module (ICM). In some cases there may be a diagnostic plug found in the corner of the engine bay (driver's side) wherein you can splice the green wire into the blue wire. If this method does not work for the late model applications you may be able to connect the green wire to a tachometer test connector wire (typically a connector with a blue wire) found behind the battery in front of the air cleaner opening on the passenger side fenderwell.

**More application information
including tech tips, FAQs, and
image diagrams are available online
at www.proformparts.com/TECH.**